

# Clamping systems

Leitz Lexicon Edition 7

Version 2

02/2024



## Explanation of abbreviations

A	= dimension A	LH	= left hand rotation
$a_e$	= cutting thickness (radial)	M	= metric thread
$a_p$	= cutting depth (axial)	MBM	= minimum order quantity
ABM	= dimension	MC	= multi-purpose steel, coated
APL	= panel raising length	MD	= thickness of knife
APT	= panel raising depth	$\text{min}^{-1}$	= revolutions per minute (RPM)
AL	= working length	MK	= morse taper
AM	= number of knives	$\text{m min}^{-1}$	= metres per minute
AS	= anti sound (low noise design)	$\text{m s}^{-1}$	= metres per second
b	= overhang	n	= RPM
B	= width	$n_{\text{max}}$	= maximum permissible RPM
BDD	= thickness of shoulder	NAL	= position of hub
BEM	= note	ND	= thickness of hub
BEZ	= description	NH	= zero height
BH	= tipping height	NL	= cutting length
BO	= bore diameter	NLA	= pinhole dimensions
CNC	= Computerized Numerical Control	NT	= grooving depth
d	= diameter	P	= profile
D	= cutting circle diameter	POS	= cutter position
D0	= zero diameter	PT	= profile depth
DA	= outside Diameter	PG	= profile group
DB	= diameter of shoulder	QAL	= cutting material quality
DFC	= Dust Flow Control (optimised chip clearance)	R	= radius
DGL	= number of links	RD	= right hand twist
DIK	= thickness	RH	= right hand rotation
DKN	= double keyway	RP	= radius of cutter
DP	= polycrystalline diamond	S	= shank dimension
DRI	= rotation	SB	= cutting width
FAB	= width of rebate	SET	= set
FAT	= depth of rebate	SLB	= slotting width
FAW	= bevel angle	SLL	= slotting length
FLD	= flange diameter	SLT	= slotting depth
$f_z$	= tooth feed	SP	= tool steel
$f_{z \text{ eff}}$	= effective tooth feed	ST	= Cobalt-basis cast alloys, e.g. Stellite®
GEW	= thread	STO	= shank tolerance
GL	= total length	SW	= cutting angle
GS	= Plunging edge	TD	= diameter of tool body
H	= height	TDI	= thickness of tool
HC	= tungsten carbide, coated	TG	= pitch
HD	= wood thickness (thickness of workpiece)	TK	= reference diameter
HL	= high-alloyed tool steel	UT	= cutting edges with irregular pitch
HS	= high-speed steel (HSS)	V	= number of spurs
HW	= tungsten carbide (TCT)	$v_c$	= cutting speed
ID	= ident number	$v_f$	= feed speed
IV	= insulation glazing	VE	= packing unit
KBZ	= abbreviation	VSB	= adjustment range
KLH	= clamping height	WSS	= workpiece material
KM	= edge breaker	Z	= number of teeth
KN	= single keyway	ZA	= number of fingers
KNL	= combination pinhole consists of 2/7/42 2/9/46,35 2/10/60	ZF	= tooth shape (cutting edge shape)
L	= length	ZL	= finger length
l	= clamping length		
LD	= left hand twist		
LEN	= Leitz standard profiles		

### Notes to the Lexicon concerning the diagrams and tables





























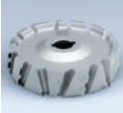

The statements made in the diagrams and tables relate to specific conditions and represent parameters from tests subjected to defined conditions. Variations when using tools in individual case due to special application conditions may be possible. Our support team will provide you with detailed information.

















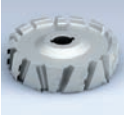









## 7. Clamping systems

	Overview clamping systems	2
	7.1. Clamping elements	6
	7.1.1 Hydro clamping - open system	6
	7.1.2 Hydro clamping - closed system	7
	7.1.3 Clamping sleeves	16
	7.2. Quick clamping elements	20
	7.2.1 Hydro clamping - closed system	20
	7.2.2 Mechanical clamping	22
	7.3. Clamping chucks	26
	7.3.1 Shrink-fit chucks	26
	7.3.2 Hydro chucks	31
	7.3.3 Collet chucks	33
	7.3.4 Weldon chucks	54
	7.3.5 Drill adaptors	56
	7.4. Clamping arbors	64
	7.4.1 Hydro clamping arbors	64
	7.4.2 Cutter arbors	68
	7.4.3 Adaptors for circular sawblades	78
	Alphabetical product index	82
	ID index	83

## 7. Clamping systems

Adaptors Tool types	 <b>Spindle without safety against twisting</b>	 <b>Spindle with safety against twisting - keyway</b>	 <b>Spindle with safety against twisting - hexagon Spindle D 30 Spindle D 40</b>	 <b>Spindle with HSK-F63 modified</b>
<b>Circular sawblades</b> 	 page 10 7.1.2 Hydro clamping - Closed system - Hydro-Duo clamping element with integrated safety against twisting  page 6 7.1.1 Hydro clamping - Open system - clamping element with clamping nut - clamping element with end ring and clamping screws	 page 16 7.1.3 Clamping sleeves - Flanged sleeve for circular sawblades with BO 65  page 22 7.2.2 Mechanical clamping - Quick clamping element Type 110 for scoring sawblades and cutting tools		 page 72 7.4.2 Arbors - Arbors HSK-F 63 modified A = 12,5, 20, 52 mm
<b>Hoggers</b> 	 page 10 7.1.2 Hydro clamping - Closed system - Hydro-Duo clamping element with integrated safety against twisting	 page 17 7.1.3 Clamping sleeves - Flanged sleeve for cutting- and hogging tools with BO 50  page 24 7.2.2 Mechanical clamping - Quick clamping element Type 160 for cutting- and hogging tools	 page 13 7.1.2 Hydro clamping - Hydro clamping element for cutting- and hogging tools for BO 60 und 80  page 20 7.2.1 Hydro clamping - Closed system - Quick clamping element Type 160 Hydro for cutting- and hogging tools  page 21 7.2.1 Hydro clamping - Closed system - Quick clamping element Type 160 Hydro-Duo for cutting- and hogging tools	 page 72 7.4.2 Arbors - Arbors HSK-F 63 modified A = 12,5, 20, 52 mm
<b>Cutters/cutterheads</b>  	 page 6 7.1.1 Hydro clamping - Open system - clamping element with clamping nut - clamping element with end ring and clamping screws  page 7 7.1.2 Hydro clamping - Closed system - clamping element with clamping nut - clamping element with end ring and clamping screws	 page 17 7.1.3 Clamping sleeves - Flanged sleeve for cutting- and hogging tools with BO 80  page 22 7.2.2 Mechanical clamping - Quick clamping element Type 110 for scoring sawblades and cutting tools	 page 13 7.1.2 Hydro clamping - Closed system - Hydro clamping element for cutting- and hogging tools for BO 60 und 80  page 11 7.1.2 Hydraulic clamping - Closed system - Hydro-clamping element for spindle d 40 for tool with bore 60  page 12 - Hydro-clamping element for spindle d 30 and for tools with bore 60	 page 63 7.4.1 Hydro clamping arbors - Hydro clamping arbor HSK-F 63 mod. for tools with bore 60  page 64 7.4.1 Hydro clamping arbors - Hydro clamping arbor HSK-F 63 mod. with stepless fine adjustment for tools with bore 60  page 72 7.4.2 Arbors - Arbors HSK-F 63 modified A = 12,5, 20, 52 mm

## 7. Clamping systems

Adaptors  Tool types	 <b>Spindle without safety against twisting</b>	 <b>Spindle with safety against twisting - keyway</b>	 <b>Spindle with safety against twisting - hexagon Spindle D 30 Spindle D 40</b>	 <b>Spindle with HSK-F63 modified</b>
<b>Cutters/cutterheads</b>  	 page 10 7.1.2 Hydro clamping - Closed system - Hydro-Duo clamping element with integrated safety against twisting	 page 24 7.2.2 Mechanical clamping - Quick clamping element Type 160 for cutting- and hogging tools	 page 20 7.2.1 Hydro clamping - Closed system - Quick clamping element Type 160 Hydro for cutting- and hogging tools  page 21 7.2.1 Hydro clamping - Closed system - Quick clamping element Type 160 Hydro-Duo for cutting- and hogging tools	
<b>Hogger sets/cutterhead sets</b>  	 page 6 7.1.1 Hydro clamping - Open system - clamping element with clamping nut - clamping element with end ring and clamping screws  page 7 7.1.2 Hydro clamping - Closed system - clamping element with clamping nut - clamping element with end ring and clamping screws  page 8 7.1.2 Hydro clamping - Closed system - Clamping element with end ring Clamping screws and safe against twisting  page 9 7.1.2 Hydro clamping - Closed system - Hydro-Duo clamping element with 2 chambers, axial piston clamping and fine adjustment  page 18 7.1.3 Clamping sleeves - Clamping sleeve with end ring and safety against twisting - Spindle filling spacers with safety against twisting  page 19 7.1.3 Clamping sleeves - Reduction sleeve with collar - Reduction sleeve without collar		 page 11 7.1.2 Hydraulic clamping - Closed system - Hydro-clamping element for spindle d 40 and for toolsets with bore 60  page 12 - Hydro-clamping element for spindle d 30 and for tool with bore 60  page 14 7.1.2 Hydro clamping - Closed system - Hydro-Duo clamping element with double piston clamping and fine adjustment  page 15 7.1.2 Hydro clamping - Closed system - Hydro-Duo clamping element with 2 chambers axial piston clamping and fine adjustment	 page 63 7.4.1 Hydro clamping arbors - Hydro clamping arbor HSK-F 63 mod. for tools with bore 60  page 64 7.4.1 Hydro clamping arbors - Hydro clamping arbor HSK-F 63 mod. with stepless fine adjustment for tools with bore 60  page 72 7.4.2 Arbors - Arbors HSK-F 63 modified A = 12,5, 20, 52 mm

## 7. Clamping systems

Adaptors Tool types	 <b>SK 30</b>	 <b>BT 30 BT 35</b>	 <b>SK 40</b>	 <b>HSK-F 50</b>
<b>Router cutters</b> 	 page 27 7.3.1 Shrink-fit chucks  page 36 page 37 page 38 7.3.3 Collet chucks	 page 39 7.3.3 Collet chucks	 page 27 7.3.1 Shrink-fit chucks  page 38 7.3.3 Collet chucks	 page 40 page 41 7.3.3 Collet chucks
<b>Cutter-heads with shank</b> 	 page 27 7.3.1 Shrink-fit chucks  page 36 page 37 page 38 7.3.3 Collet chucks	 page 39 7.3.3 Collet chucks	 page 27 7.3.1 Shrink-fit chucks  page 38 7.3.3 Collet chucks	 page 40 page 41 7.3.3 Collet chucks
<b>Tools with borehole</b> 	 page 68 page 69 7.4.2 Arbors	 page 67 7.4.2 Arbors +  page 39 7.3.3 Collet chucks	 page 68 page 69 7.4.2 Arbors	 page 67 7.4.2 Arbors +  page 40 page 41 7.3.3 Collet chucks
<b>Circular sawblades</b> 	 page 79 7.4.3 Adaptors for sawblades +  page 68 page 69 7.4.2 Arbors		 page 79 7.4.3 Adaptors for sawblades +  page 68 page 69 7.4.2 Arbors	
<b>Drills with cylindrical shank</b> 	 page 27 7.3.1 Shrink-fit chucks  page 36 page 37 page 38 7.3.3 Collet chucks  page 61 7.3.5 Drill chucks	 page 39 7.3.3 Collet chucks	 page 27 7.3.1 Shrink-fit chucks  page 38 7.3.3 Collet chucks  page 61 7.3.5 Drill chucks	 page 40 page 41 7.3.3 Collet chucks
<b>Drills with cylindrical shank with clamping area</b> 	 page 27 7.3.1 Shrink-fit chucks  page 36 page 37 page 38 7.3.3 Collet chucks  page 61 7.3.5 Drill chucks	 page 39 7.3.3 Collet chucks	 page 27 7.3.1 Shrink-fit chucks  page 38 7.3.3 Collet chucks  page 61 7.3.5 Drill chucks	 page 40 page 41 7.3.3 Collet chucks

## 7. Clamping systems

 <b>HSK-E 63</b>	 <b>HSK-F 63</b>	 <b>HSK 85 WS</b>	 <b>Threaded shank with/without tapered seating</b>
 page 28 7.3.1 Shrink-fit chucks  page 42 page 43 7.3.3 Collet chucks	 page 28 7.3.1 Shrink-fit chucks  page 32 7.3.2 Hydro chucks  page 44 page 45 page 46 7.3.3 Collet chucks	 page 47 7.3.3 Collet chucks	
 page 28 7.3.1 Shrink-fit chucks  page 42 page 43 7.3.3 Collet chucks	 page 28 7.3.1 Shrink-fit chucks  page 32 7.3.2 Hydro chucks  page 44 page 45 page 46 7.3.3 Collet chucks	 page 47 7.3.3 Collet chucks	
 page 63 7.4.1 Hydro clamping arbors  page 70 7.4.2 Arbors	 page 63 7.4.1 Hydro clamping arbors  page 71 7.4.2 Arbors	 page 65 7.4.1 Hydro clamping arbors  page 73 page 74 page 75 7.4.2 Arbors	
 page 79 7.4.3 Adaptors for circular saws +  page 70 7.4.2 Arbors	 page 79 7.4.3 Adaptors for multi purpose saws +  page 71 7.4.2 Arbors  page 78 7.4.3 Adaptors for circular saws		
 page 28 7.3.1 Shrink-fit chucks  page 42 page 43 7.3.3 Collet chucks  page 61 7.3.5 Drill chucks	 page 28 7.3.1 Shrink-fit chucks  page 44 page 45 page 46 7.3.3 Collet chucks  page 61 7.3.5 Drill chucks		
 page 28 7.3.1 Shrink-fit chucks  page 42 page 43 7.3.3 Collet chucks  page 61 7.3.5 Drill chucks	 page 28 7.3.1 Shrink-fit chucks  page 44 page 45 page 46 7.3.3 Collet chucks  page 61 7.3.5 Drill chucks		 page 58 7.3.5 Drill chucks quick clamping design  page 57 7.3.5 Conventional drill chucks

## 7. Clamping systems

### 7.1 Clamping elements

#### 7.1.1 Hydro clamping - open system



#### For spindle without safety device against twisting

##### Application:

Clamping sleeve for centric, play-free clamping of tools and cutterheads.

##### Machine:

Machines with high precision spindles e.g. moulders etc.

##### Technical information:

Hydro-Duo open clamping system, activation of hydro clamping by a grease gun. Suitable for right and left hand rotation.

##### With clamping nut

PH 130 0 01

d	BO	NL	L	GL	ND	DB	ID
mm	mm	mm	mm	mm	mm	mm	
60	40	60	75	100	100	102	030503 ●
60	45	60	75	100	100	102	030505 ●
60	50	60	75	100	100	102	030507 ●
60	50	40	55	80	80	102	030515 ●

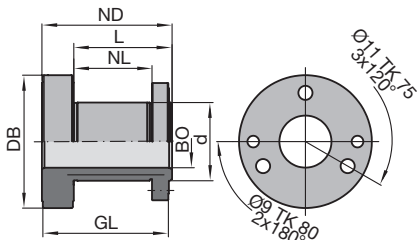

Hydro-Duo clamping element  
PH 130 0 01 with clamping nut

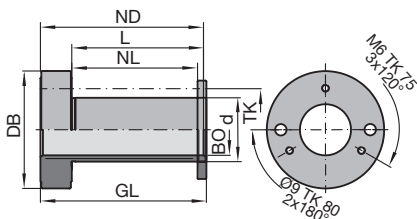

Hydro-Duo clamping element  
PH 130 0 02 with end ring and clamping  
screws

##### Spare parts:

BEZ	ABM	ID
	mm	
Sickle spanner adjustable	D90/155; L290; DIN1816; tenon 6	005462 ●
Grease gun		008239 ●
Grease cartridge	for Hydro sleeve	007934 ●
Grease nipple	M10x1	007935 ●

##### With end ring and clamping screws

PH 130 0 02

d	BO	NL	L	GL	ND	DB	TK	ID
mm	mm	mm	mm	mm	mm	mm	mm	
50	40	98	105	130	100	92	65	030600 ●
60	50	98	105	130	130	102	75	030602 ●

##### Spare parts:

BEZ	ABM	ID
	mm	
Allen key	SW 5	005452 ●
Grease gun		008239 ●
Grease cartridge	for Hydro sleeve	007934 ●
Grease nipple	M10x1	007935 ●
Cylindrical screw with ISK	M6x70	005936 ●
Cylindrical screw with ISK	M6x120	005942 ●

##### Clamping collars without thread

TD 870 0

D	B	BO	ID
mm	mm	mm	
100	25	40	030700 ●
100	25	45	030701 ●
100	25	50	030702 ●

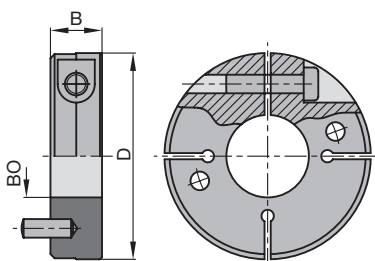

Clamping collar without thread



## 7. Clamping systems

### 7.1 Clamping elements

#### 7.1.2 Hydro clamping - closed system



#### For spindle without safety device against twisting

##### Application:

Clamping sleeve for centric clamping of tools, tool sets and cutterheads.

##### Machine:

Machines with high precision spindles, e.g. moulders, double-end tenoners, edgbanding machines, window production machines etc.

##### Technical information:

Hydro-Duo closed hydro clamping system, activation of hydro clamping by internal clamping system without grease gun. Suitable for right and left hand rotation.

##### With clamping nut

PH 130 0 05

d	BO	NL	L	GL	ND	DB	ID
mm	mm	mm	mm	mm	mm	mm	
60	45	63	77	100	100	122	<b>031603</b>
60	50	63	77	100	100	122	<b>031601 ●</b>
70	60	43	57	80	80	130	<b>031605</b>

##### Spare parts:

BEZ	ABM	ID
	mm	
Sickle spanner adjustable	D90/155; L290; DIN1816; tenon 6	<b>005462 ●</b>

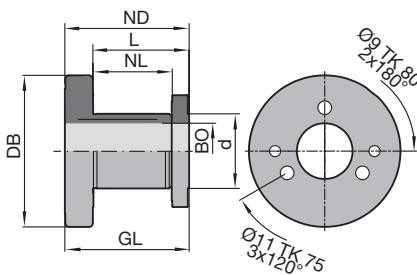

Hydro-Duo clamping element  
PH 130 0 05 with clamping nut

##### With end ring and clamping screws

PH 130 0 06

d	BO	NL	L	GL	ND	DB	TK	ID
mm	mm	mm	mm	mm	mm	mm	mm	
60	50	52	60	83	83	122	75	<b>031650 ●</b>

##### Spare parts:

BEZ	ABM	ID
	mm	
Allen key	SW 5	<b>005452 ●</b>
Cylindrical screw with ISK	M6x70	<b>005936 ●</b>

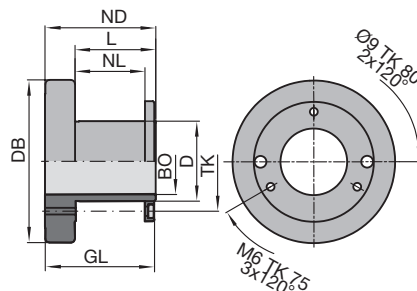

Hydro-Duo clamping element  
PH 130 0 06 with end ring and clamping  
screws

##### Clamping collars without thread

TD 870 0

D	B	BO	ID
mm	mm	mm	
100	25	45	<b>030701 ●</b>
100	25	50	<b>030702 ●</b>

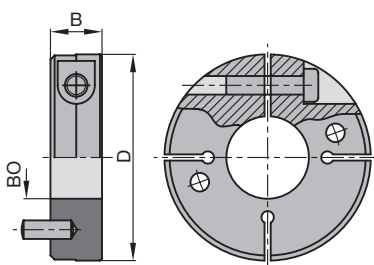

Clamping collar without thread



#### For spindle without safety device against twisting

**Application:**

Clamping sleeve for centric, play-free clamping of tool sets, for window tools on stacked spindle machines.

**Machine:**

Machines with high precision spindles, e.g. moulders, double-end tenoners, edgebanding machines, window production machines etc.

**Technical information:**

Hydro-Duo closed hydro clamping system, activation of hydro clamping by internal clamping system without grease gun.

Total length of sleeves adjusted as required.

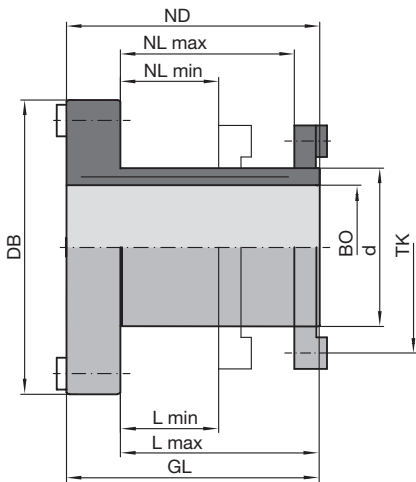

Hydro-Duo clamping element PH 130 0 13 with end ring, clamping screws and safety device against twisting

#### With end ring, clamping screws and safety device against twisting

PH 130 0 13

d	BO	NL	L	GL	ND	DB	TK	ID
mm	mm	mm	mm	mm	mm	mm	mm	
50	40	35 - 55	43 - 63	80	80	93	65	031658 □
50	40	55 - 75	63 - 83	100	100	93	65	031659 □
50	40	75 - 95	83 - 103	120	120	93	65	031660 ●
60	40	95 - 115	103 - 123	140	140	93	75	031661 ●
60	50	35 - 55	43 - 63	80	80	93	75	031655 ●
60	50	55 - 75	63 - 83	100	100	93	75	031652 ●
60	50	75 - 95	83 - 103	120	120	93	75	031653 ●
60	50	95 - 115	103 - 123	140	140	93	75	031654 ●
60	50	115 - 135	123 - 143	160	160	93	75	031657 ●

**Spare parts:**

BEZ	ABM	BEM	ID
	mm		
Cylindrical screw with ISK	M6x50		005932 ●
Cylindrical screw with ISK	M6x70		005936 ●
Cylindrical screw with ISK	M6x90		005939
Cylindrical screw with ISK	M6x100		005940 ●
Cylindrical screw with ISK	M6x110		005941 ●
Cylindrical screw with ISK	M6x130		006542 ●
Cylindrical screw with ISK	M6x150		006400 ●
Countersink screw, Torx® 15	M4x6	for feather key 3	007436 ●
Countersink screw, Torx® 15	M4x10-12.9	for feather key 1,2,4	007437 ●
Feather key 1	19x8x7		008525 ●
Feather key 2	10x8.5x6.5		008526 ●
Feather key 3	19x8x3.5		008527 ●
Feather key 4	19x8x7		008528 ●
Allen key	SW 5		005452 ●
Torx® key	Torx® 15		117507 ●

#### End ring with safety device against twisting

TR 112 0

D	BO	TK	B	ID
mm	mm	mm	mm	
85	50	65	8	008245 ●
93	60	75	8	008222 ●

## 7. Clamping systems

### 7.1 Clamping elements

#### 7.1.2 Hydro clamping - closed system



#### Spindle without safety device against twisting - Hydro-Duo clamping sleeve with stepless fine adjustment of 2 part tool sets

**Application:**

Hydro-Duo clamping sleeve with fine thread and axial piston clamping for stepless adjustment of 2 part tool sets. Additional clamping collar with safety device against twisting.

**Machine:**

Machines with high precision spindles, e.g. moulders, double-end tenoners, edge-banding machines etc.

**Technical information:**

High precision fine thread adjustment with a 0.01 mm scale for fine adjustment of 2 part cuttersets with repeatability. Adjustment range 10 mm. Maintenance free hydro clamping mechanism.



**With Hydro-Duo 2 chamber axial piston clamping and fine adjustment**

PH 130 0 11

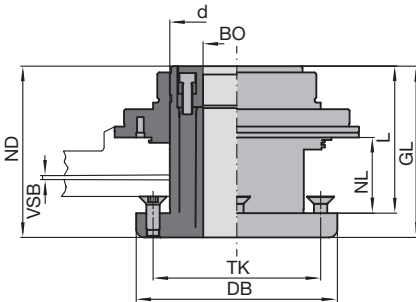

d	BO	BO	NL	L	GL	ND	DB	VSB	TK	ID
mm	mm	in	mm	mm	mm	mm	mm	mm	mm	
80	40		33.5 - 43.5	88	108	108	120	10	100	031555 □
100	50		60 - 70	102	117	117	140	10	120	030566 □
100	53.97	2 1/8"	60 - 70	102	112	117	140	10	120	031552 □

**Spare parts:**

BEZ	ABM	ID
	mm	
Allen key	SW 5	005452 ●

Hydro-Duo clamping element with axial piston clamping and fine adjustment  
PH 130 0 11

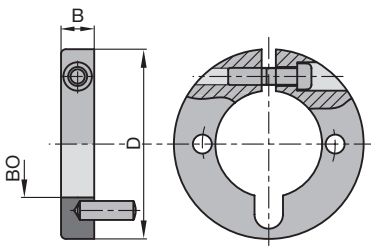

Clamping collar without thread

**Clamping collars without thread**

TD 870 0

D	B	BO	BO	ID
mm	mm	mm	in	
80	14	40		030713 ●
80	14	45		030714 ●
80	14	46.04	1 13/15"	030715 ●
80	14	50		030716 ●
80	14	53.97	2 1/8"	030717 ●

## 7. Clamping systems

### 7.1 Clamping elements

#### 7.1.2 Hydro clamping - closed system



### For spindle without safety device against twisting - Hydro-Duo clamping sleeve for saws, cutters and hoggers

**Application:**

Hydro-Duo clamping sleeve for high precision clamping and flexible positioning of saws, cutters and hoggers on spindles without using spacers or spindle nuts.

**Machine:**

Multi-blade circular saw machines, four-sided moulders, double-end tenoners etc.

**Technical information:**

Closed hydro clamping system with maintenance free pressure piston mechanism.



**With integrated safety device against twisting**

PH 130 0 10

d	BO	NLA	NL	L	GL	ND	DB	TK	ID
mm	mm	mm	mm	mm	mm	mm	mm	mm	mm
60	40	3/M6/75	35	35	69	69	100	75	030572 ●
60	50	3/M6/75	35	35	69	69	100	75	030574 ●
90	70	6/M6/106	35	35	70	70	120	106	030571
115	100	6/M6/131	14	14	49.5	49.5	145	131	030557 ●
115	100	6/M6/131	48.5	48.5	84	84	145	131	030555 ●

with clamping screws.

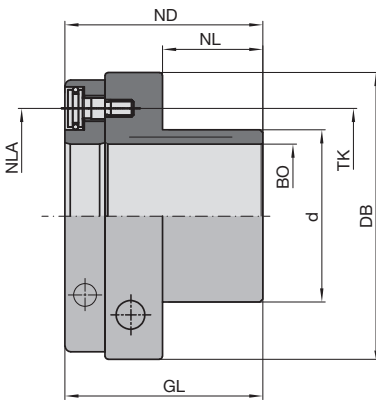

**Spacer set, aluminium screwed, for mounting saws**

AT 102 0

D	B	BO	NLA	ID
mm	mm	mm	mm	mm
120	30	90	6/7/106	028482 ●
145	44	115	6/7/131	028480 ●

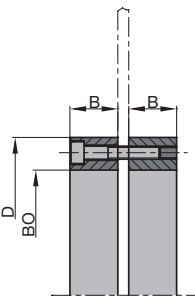

**Steel spacers, for mounting sets of sawblades**

TR 100 0

D	B	BO	NLA	ID
mm	mm	mm	mm	mm
120	0.5	90	8/7/106	028679 ●
120	1	90	8/7/106	028680 ●
120	3	90	8/7/106	028681
120	5	90	8/7/106	028682
145	0.5	115	8/7/131	028683 ●
145	1	115	8/7/131	028684 ●
145	3	115	8/7/131	028685 ●
145	5	115	8/7/131	028686

Set of spacers

Bore pattern for tools for mounting on:

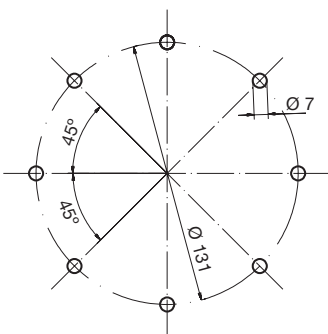

Hydro sleeve ID 030555 and 030557

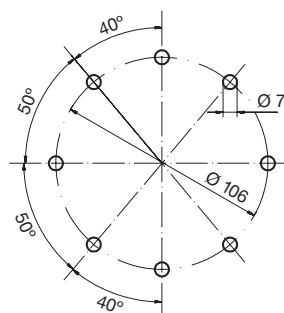

Hydro sleeve ID 030571

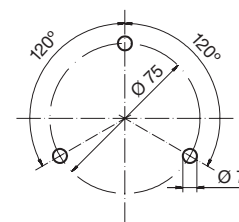

Hydro sleeve ID 030572 und 030574

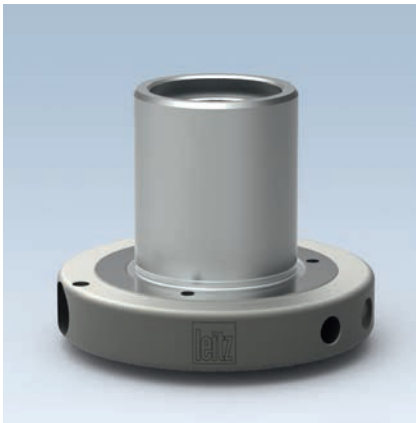

### Spindle with safety device against twisting - hexagon HF spindle 40 Hydro-Duo clamping sleeve

**Application:**

Hydro-Duo clamping element for play-free clamping of cutting tools on high precision spindle with hexagon safety device against twisting (HF spindle) for high concentricity.

**Machine:**

Machines with high precision spindles, e.g. moulders, double-end tenoners, edgbanding machines etc.

**Technical information:**

Closed hydro clamping system with maintenance free pressure piston mechanism. RPM  $n_{max}$  12000 min<sup>-1</sup>.

**Attention:** Comply with maximum admissible speed for the mounted tools!



**With end ring and clamping screws, for tool sets with bore 60 mm**

PH 130 0 04

d	BO	NL	L	GL	ND	DB	TK	ID
mm	mm	mm	mm	mm	mm	mm	mm	
60	40	68	68	96.5	88	118	75	<b>030559 ●</b>

Spindle fixture consisting of:

Conical spring washer, clamping screw, hexagon spanner, brace.

**Spare parts:**

BEZ	ABM	ID
	mm	
Securing part	for HF-spindle HF 40	<b>066473 ●</b>
Allen key	SW 5	<b>005452 ●</b>

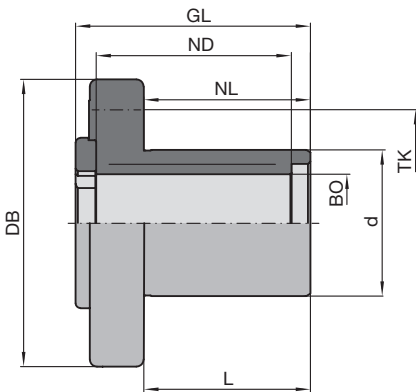

Hydro Duo clamping element  
PH 130 0 04



### Spindle with safety device against twisting - hexagon HF spindle 30 Hydro clamping sleeve

**Application:**

Hydro clamping sleeve for play-free clamping of cutting tools on high precision spindle with hexagon safety device against twisting (HF spindle 30) for high concentricity.

**Machine:**

Machines with high precision spindles diameter 30 mm, e.g. edgebanding machines, double-end tenoners, moulders etc.

**Technical information:**

Closed hydro clamping system with maintenance free pressure piston mechanism. User friendly axial handling of the hydro clamping screw from top. Safety against twisting on the spindle through an appropriate hexagon in the spindle fixture.

RPM  $n_{max}$  12000 min<sup>-1</sup>.

**Attention:** Comply with maximum admissible speed for the mounted tools!

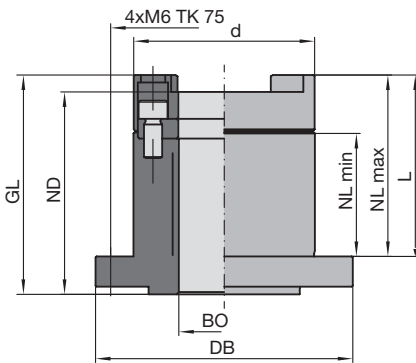

Hydro clamping sleeve PH 130 0

**For cutting tools with bore 60 mm**

PH 130 0

d	BO	NL	L	GL	ND	DB	TK	ID
mm	mm	mm	mm	mm	mm	mm	mm	
60	30	40 - 60	60	72.5	67	85	75	<b>030567 ●</b>

Spindle securing part consists of:

Securing parts, clamping screw, hexagon spanner, brace.

**Spare parts:**

BEZ	ABM	ID
	mm	
Securing part	for HF-spindle HF 30	<b>066563 ●</b>
Allen key	SW 5, L 150	<b>005501 ●</b>



### Spindle with safety device against twisting - hexagon HF spindle 40 Hydro clamping sleeve

**Application:**

Hydro clamping sleeve for play-free clamping of hogging/cutting tools on high precision spindle with hexagon safety device against twisting (HF spindle) for high concentricity.

**Machine:**

Machines with high precision spindles, e.g. moulders, double-end tenoners, edgbanding machines etc.

**Technical information:**

Closed hydro clamping system with maintenance free pressure piston mechanism. RPM  $n_{max}$  12000 min<sup>-1</sup>.

**Attention:** Comply with maximum admissible speed for the mounted tools!



**For cutting tools and hoggers with bore 60/80 mm**

PH 130 0 03

d	BO	NL	L	GL	ND	DB	TK	ID
mm	mm	mm	mm	mm	mm	mm	mm	
60	40	18	18	96.5	80.3	118	100	<b>061702 ●</b>
80	40	18	18	96.5	80.3	118	100	<b>061703 ●</b>

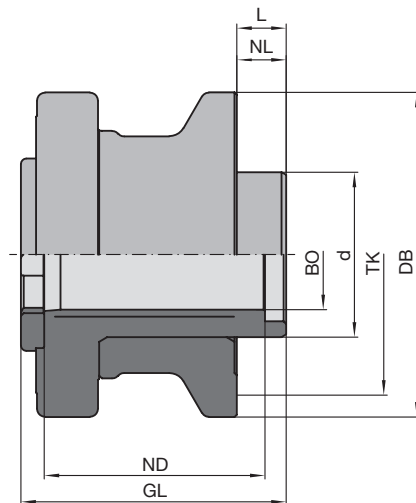

Spindle fixture consisting of:

Conical spring washer, clamping screw, hexagon spanner, brace.

**Spare parts:**

BEZ	ABM	ID
	mm	
Securing part	for HF-spindle HF 40	<b>066473 ●</b>

Hydro clamping sleeve PH 130 0 03



### Spindle with safety device against twisting - hexagon HF spindle 40 Hydro-Duo clamping sleeve, adjustable

#### Application:

Hydro-Duo clamping sleeve for play-free clamping of cutting tools on high precision spindle with hexagon safety device against twisting (HF spindle). With extra fine thread and dual piston clamping for stepless adjustment of 2 part tool sets on the spindle.

#### Machine:

Machines with high precision spindles, e.g. moulders, double-end tenoners, edgelanding machines etc.

#### Technical information:

Closed hydro clamping system with maintenance free pressure piston mechanism. RPM  $n_{max}$  12000 min<sup>-1</sup>.

Dual piston clamping, independent clamping: sleeve - spindle and sleeve - tool.

**Attention:** Comply with maximum admissible speed for the mounted tools!

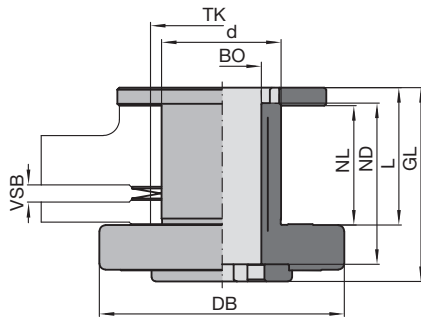

Hydro-Duo clamping sleeve with fine adjustment PH 130 0 07

#### With dual piston clamping and hexagon safety device against twisting, fine adjustment

PH 130 0 07

d	BO	NL	L	GL	ND	DB	TK	VSB	ID
mm	mm	mm	mm	mm	mm	mm	mm		
60	40	57 - 59	68	96.5	80	122	75	2	030553 ●
60	40	49 - 59	68	106.5	80	122	75	10	030556 ●

Included in delivery: Duo sleeve complete with parts for mounting cutter and adjusting mechanism.

#### Spare parts:

BEZ	ABM	ID
	mm	
Allen key	SW 5	005452 ●



## 7. Clamping systems

### 7.1 Clamping elements

#### 7.1.2 Hydro clamping - closed system



#### Spindle with safety device against twisting - hexagon HF spindle 40 Hydro-Duo clamping sleeve, adjustable

**Application:**

Hydro-Duo clamping sleeve for play-free clamping of cutting tools on high precision spindle with hexagon safety device against twisting (HF spindle). Model with extra fine thread and axial dual piston clamping for stepless adjustment of 2 part tool sets on the spindle.

**Machine:**

Machines with high precision spindles, e.g. moulders, double-end tenoners, edgbanding machines etc.

**Technical information:**

Closed Hydro-Duo clamping system with axial dual piston clamping, independent clamping: sleeve - spindle and sleeve - tool.

**With dual piston clamping and hexagon safety device against twisting, fine adjustment**

PH 130 0 14

d	BO	NL	L	GL	ND	DB	TK	VSB	ID
mm	mm	mm	mm	mm	mm	mm	mm	mm	
80	40	33.5 - 43.5	88	108	80	120	100	10	031560 □
80	40	44.4 - 54.4	88	108	80	120	100	10	030562 □

**Spare parts:**

BEZ	ABM	ID
	mm	
Allen key	SW 5	005452 ●

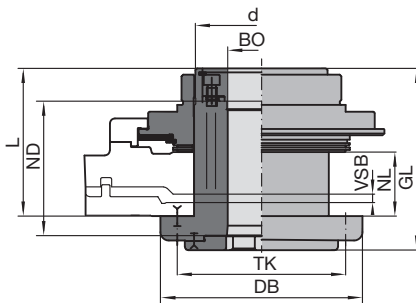

Hydro-Duo clamping element with axial piston clamping and fine adjustment  
PH 130 0 14



#### Flanged sleeve

**Application:**

Flanged sleeve for mounting scoring and grooving sawblades.

**Machine:**

Double-end tenoners, edgebanding machines etc.

**Technical information:**

For standard spindle (DKN). Case hardened steel tool body with high concentricity. Spindle fixing parts are supplied by the machine manufacturer.

**For circular sawblades with bore 65 mm**

TB 300 0

Machine	d mm	BO mm	NL mm	L mm	GL mm	ND mm	DB mm	TK mm	ID
Homag, IMA	65	30 DKN	2.2	2.2	95	63	110	90	<b>065600 ●</b>
Homag, IMA	65	35 DKN	2.2	2.2	95	63	110	90	<b>065606 ●</b>

When ordering ID **65600**, check whether locking disk ID **66567** is required.

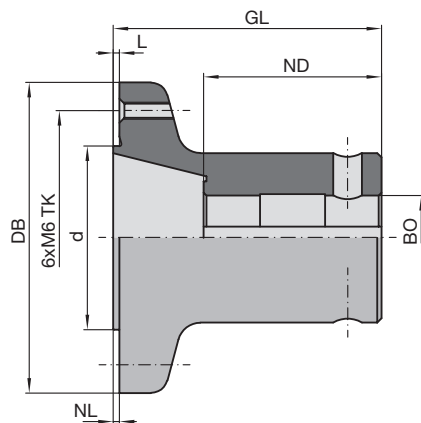

Flanged sleeve TB 300 0

**Spare parts:**

BEZ	Machine	ABM mm	ID
Countersink screw with ISK		M6x10	<b>005780 ●</b>
Spindle fixture left for sleeve ID 65600	Homag, IMA	48x24x18	<b>066561 ●</b>
Spindle fixture right for sleeve ID 65600	Homag, IMA	48x24x18	<b>066562 ●</b>
Spindle fixture left for sleeve ID 65606	Homag, IMA	60x18x21	<b>116015 ●</b>
Spindle fixture right for sleeve ID 65606	Homag, IMA	60x18x21	<b>116016 ●</b>
Locking disc for sleeve ID 65600	Homag, IMA	40x9x17	<b>066567 ●</b>

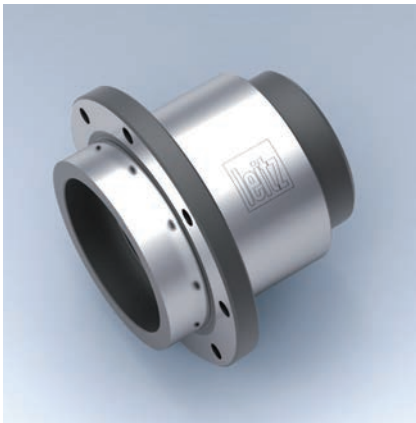

#### Flanged sleeve

##### Application:

Flanged sleeve for mounting hoggers, segment hoggers, solid hoggers and folding hoggers.

##### Machine:

Double-end tenoners, finger joint machines, edgebanding machines etc.

##### Technical information:

For standard spindle (with or without keyway). Case hardened steel tool body with high concentricity. Spindle fixing parts are supplied by the machine manufacturer.

##### For cutting and hogging tools with bore 80 mm

TB 300 0, TB 300 0 01, TB 300 0 03, TB 300 0 06, TB 300 0 08, TB 300 0 11, TB 300 0 12

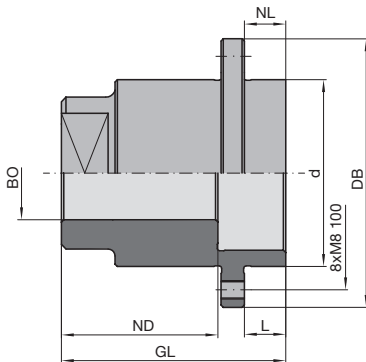

Flanged sleeve TB 300 0

Machine	d	BO	NL	L	GL	ND	DB	TK	ID
	mm	mm	mm	mm	mm	mm	mm	mm	mm
Schwabedissen	80	40 DKN	17.7	17.7	82	53	115	100	<b>061654 ●</b>
Torwegge	80	35 DKN	17.7	17.7	90	63	115	100	<b>061655 ●</b>
Celaschi	80	35 KN	17.7	17.7	95	65	115	100	<b>061652 ●</b>
Grecon, Weinig	80	30 KN	17.7	17.7	75	45	115	100	<b>061660 ●</b>
Homag, IMA	80	35 DKN	17.7	17.7	90	63	115	100	<b>061650 ●</b>
Homag	80	35 DKN	17.7	17.7	104	63	115	100	<b>061685 ●</b>
* Gabbiani	80	40 DKN	17.7	17.7	82	52	115	100	<b>061657 ●</b>
Dimter, Grecon, Weinig	80	40 DKN	12.7	12.7	59	44	113	100	<b>061679 ●</b>

\* = L and KLH values include 13 mm spacer thickness.

##### Spare parts:

BEZ	ABM	ID
	mm	
Cylindrical screw with ISK	M8x18	<b>005945 ●</b>
Cylindrical screw with ISK	M8x20	<b>005946 ●</b>



#### Clamping sleeve with end ring

**Application:**

Clamping sleeve for mounting sets of single tools.

**Machine:**

Spindle moulders, moulders, double-end tenoners, edgebanding machines and window production machines.

**Technical information:**

Suitable for the use with several tool sets mounted on top of each other e.g. stacked spindle machines.

**With end ring and safety device against twisting**

TB 260 0

d	BO	NL	L	GL	ND	DB	TK	ID
mm	mm	mm	mm	mm	mm	mm	mm	
50	40	96	104	112	112	77	65	029676 ●
60	40	96	104	112	112	90	75	029677 ●
60	40	84	92	100	100	90	75	029678 ●
60	50	84	92	100	100	90	75	029679 ●
60	50	79	87	95	95	90	75	029680 ●
60	50	64	72	80	80	90	75	029697 ●

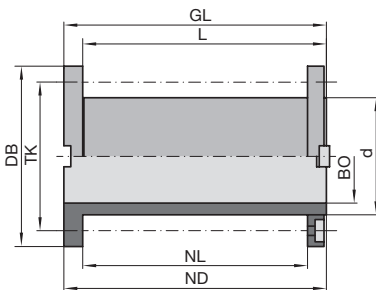

Clamping sleeve TB 260 0 with end ring and safety device against twisting

**Spare parts:**

BEZ	for L	ABM	ID
	mm	mm	
Cylindrical screw with ISK	80	M6x74	007075 ●
Cylindrical screw with ISK	100	M6x94	007077 ●
Cylindrical screw with ISK	112	M6x106	007078 ●
Countersink screw, Torx® 15		M4x10-12.9	007437 ●
Feather key		B 8x7x16	008506 ●
Allen key		SW 5	005452 ●
Torx® key		Torx® 15	117507 ●

**Application:**

Spacer element for use with clamping sleeves with safety device against twisting to fill free spindle lengths.

**Spindle filler spacers with safety device against twisting**

TR 112 0

d	BO	NL	ID
mm	mm	mm	
77	50	60	027875 ●
77	50	80	027876 ●
77	50	100	027878

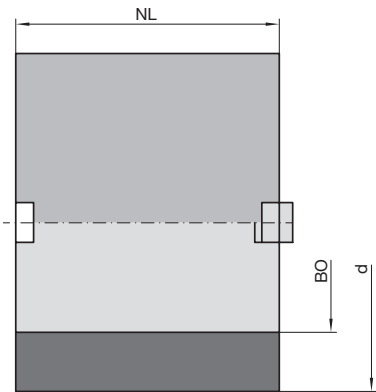

Spacer with safety device against twisting



#### Reducing sleeve

**Application:**

Reducing sleeve with/without flange for cutting tools and tool sets for use on spindles of various diameters.

**Machine:**

Spindle moulders, plug cutters etc.

**Technical information:**

The length of the reducing sleeve should be approximately 2 mm shorter than the width of the hub or the total height of the tool/tool set.

For safety reasons, the use of reducing sleeves should be avoided if possible.



**With flange**

TB 200 0

d	BO	BO	NL	GL	DB	BDD	ID
mm	mm	in	mm	mm	mm	mm	
30	25		18	22	50	4	028201 ●
35	30		18	23	55	5	028204 ●
40	30		18	24	60	6	028206 ●
40	35		18	24	60	6	028207 ●
40	31.75	1 1/4"	18	24	60	6	028220 ●
50	30		18	24	70	6	028208 ●
50	35		18	24	70	6	028210 ●
50	40		18	24	70	6	028211 ●
50	45		18	24	70	6	028209 ●
60	30		18	24	80	6	028212 ●
60	40		18	24	80	6	028214 ●
60	50		18	24	80	6	028216 ●

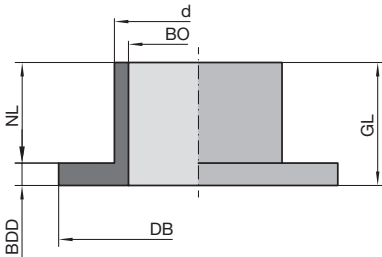

Reducing sleeve TB 200 0 with flange

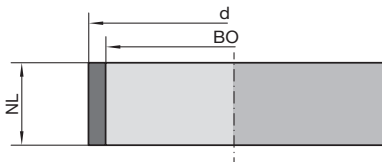

Reducing sleeve TB 100 0 01 without flange

**Without flange**

TB 100 0 01

d	BO	NL	ID
mm	mm	mm	
35	30	10	028290 ●
35	30	40	028293 ●
35	30	60	028294 ●
35	30	96	028295 ●
40	30	20	028296 ●
40	30	40	028298 ●
40	30	53	028300 ●
40	30	60	028301 ●
40	30	96	028302 ●
40	35	30	028304 ●
40	35	40	028305 ●
40	35	60	028306 ●
40	35	96	028307 ●
50	40	96	028310 ●

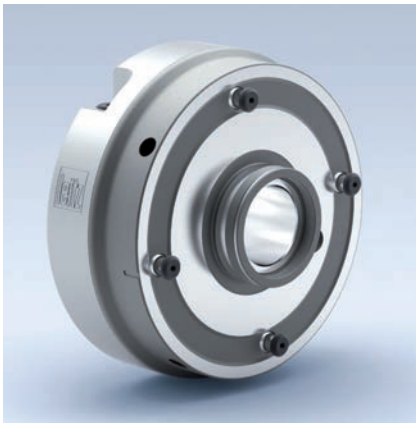

### Spindle with safety device against twisting - hexagon HF spindle 40 Quick clamping sleeve type 160 Hydro

#### Application:

Quick clamping sleeve for tools and hoppers on high precision spindle  $D = 40$  mm with hexagon safety device against twisting.

#### Machine:

Double-end tenoners, edgebanding machines etc.

#### Technical information:

Hardened steel tool body, with mechanical quick clamping mechanism without compressed air. Tool is mounted directly on the quick clamping system without intermediate flange, closed hydro clamping system with maintenance free pressure piston mechanism, suitable for right hand and left hand rotation.

$RPM n_{max} = 9000 \text{ min}^{-1}$ . Tools must have four bayonet holes on 130 mm pitch.

**Attention:** Comply with maximum admissible speed for the mounted tools!

#### For tools and hoppers

PH 110 0 01

d	BO	NL	L	GL	ND	DB	TK	Clamping bolts	ID
mm	mm	mm	mm	mm	mm	mm	mm	PCS	
60	40	17.7	17.7	95.7	80	170	130	4	<b>150100 ●</b>

#### Spare parts:

BEZ	ABM	ID
	mm	
Securing part	for HF-spindle HF 40	<b>066473 ●</b>
Hexagon key	SW 6	<b>117516 ●</b>

Spindle securing part consists of:

Conical spring washer, clamping screw, hexagon spanner, brace.

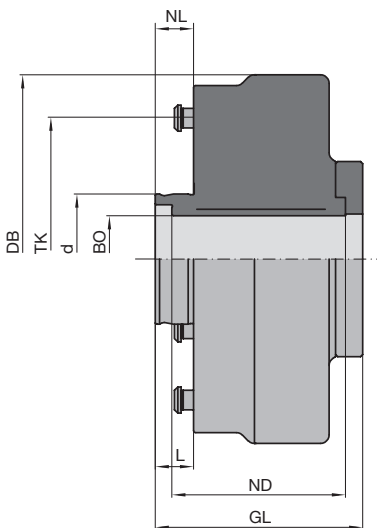

Hydro quick clamping sleeve  
type 160 HF



### Spindle with safety device against twisting - hexagon HF spindle 40 Quick clamping sleeve type 160 Hydro-Duo

#### Application:

Quick clamping sleeve for tools and hoppers on high precision spindle  $D = 40$  mm with hexagon safety device against twisting. Double acting hydro centering clamping eliminating the tolerance between spindle, clamping element and tool.

#### Machine:

Double-end tenoners, edgebanding machines etc.

#### Technical information:

Hardened steel tool body, with mechanical quick clamping mechanism without compressed air. Tool is mounted directly on the quick clamping system without intermediate flange, closed hydro clamping system with maintenance free pressure piston mechanism, suitable for right hand and left hand rotation.

RPM  $n_{max} = 9000 \text{ min}^{-1}$ . Tools must have four bayonet holes on 130 mm pitch.

**Attention:** Comply with maximum admissible speed for the mounted tools!



#### For tools and hoppers

PH 110 0 02

d	BO	NL	L	GL	ND	DB	TK	Clamping bolts	ID
mm	mm	mm	mm	mm	mm	mm	mm	PCS	
60	40	32	32	96.5	80	170	130	4	<b>150200 ●</b>

#### Spare parts:

BEZ	ABM	ID
	mm	
Securing part	for HF-spindle HF 40	<b>066473 ●</b>
Hexagon key	SW 6	<b>117516 ●</b>

Spindle securing part consists of:

Conical spring washer, clamping screw, hexagon spanner, brace.

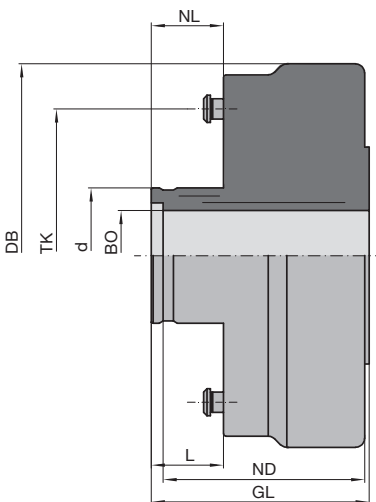

Hydro-Duo quick clamping sleeve type 160 HF



### Spindle with safety device against twisting - keyway Quick clamping sleeve type 110

**Application:**

For quick clamping of scoring sawblades, grooving sawblades and tools.

**Machine:**

Double-end tenoners, finger joint machines, edgebanding machines etc.

**Technical information:**

For standard spindle (DKN), hardened steel tool body with mechanical operation of the quick clamping mechanism without compressed air. Tool is mounted directly or by using a flange, suitable for right hand rotation and left hand rotation.

**For scoring sawblades and tools**

PM 110 0 01

d	BO	NL	L	GL	ND	DB	TK	Clamping bolts	ID
mm	mm	mm	mm	mm	mm	mm	mm	PCS	
50	30	DKN	15.5	15.5	72	47.5	116	80	3
									<b>150000 ●</b>

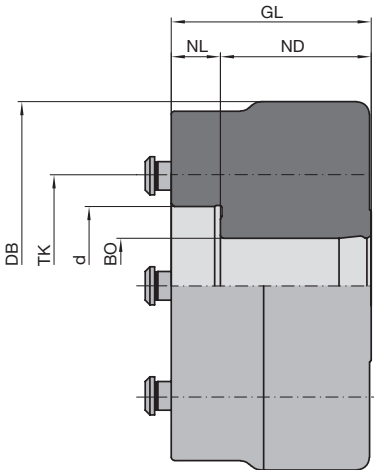

**Spare parts:**

BEZ	Machine	ID	ID
		LH	RH
Securing part	IMA	<b>066477 ●</b>	<b>066477 ●</b>
Securing part	Homag	<b>066541 ●</b>	<b>066540 ●</b>
Hexagon key			<b>117516 ●</b>

Spindle securing part consists of:

Conical spring washer, clamping nut or clamping screw, spanner or hexagon spanner, brace.

**Application:**

Spacer for flush mounting when using flanges type 110/2.

**Machine:**

Double-end tenoners, finger joint machines, edgebanding machines etc.

**Spacer for flush mounting**

TR 111 0

Machine	ABM	ABM-spindle	ID
	mm	mm	
Homag, IMA	60x26x30.DKN	30 DKN x68	<b>028800 ●</b>

Quick clamping sleeve

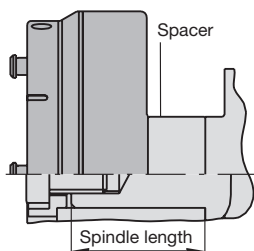

Quick clamping sleeve, flush mounted on spindle



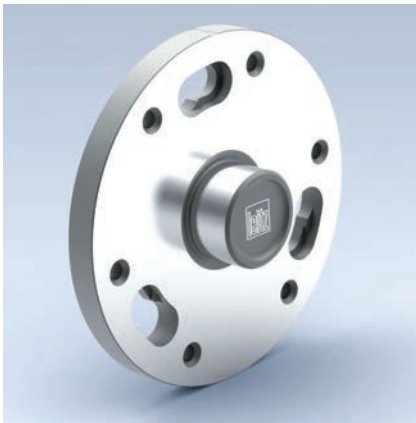

### Spindle with safety device against twisting - keyway tool flange type 110

**Application:**

Tool flange for quick clamping sleeve type 110. Hardened steel tool body for quick clamping of scoring/grooving sawblades.

**Machine:**

Double-end tenoners, finger joint machines, edgebanding machines etc.

**Technical information:**

Tool mounted directly on tool flange. RPM  $n_{max}$  12000 min<sup>-1</sup>.

**Attention:** Comply with maximum admissible speed for the mounted tools!

**Tool flange**

TD 883 0 01

Tool Type

ID

ID

110/2 for scoring saws mounted on flange

LH

RH

159051 • 159052 •

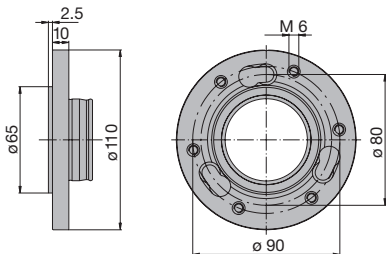

Tool flange type 110/2 for scoring saws



### Spindle with safety device against twisting - keyway Quick clamping sleeve type 160

**Application:**

For quick clamping of hoggers and tools.

**Machine:**

Double-end tenoners, edgebanding machines etc.

**Technical information:**

For standard spindle (KN/DKN). Hardened steel tool body, with mechanical operation of the quick clamping mechanism without compressed air. Tool is mounted directly on the quick clamping sleeve or by a flange, suitable for right hand rotation and left hand rotation. RPM  $n_{max}$  9000 min<sup>-1</sup>.

**Attention:** Comply with maximum admissible speed for the mounted tools!

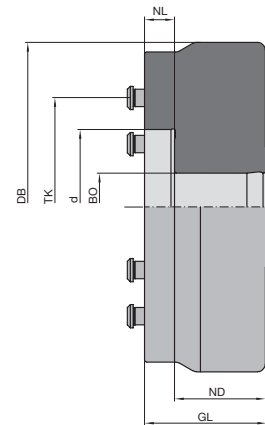

**For tools and hoggers**

PM 110 0 01

d	BO	NL	L	GL	ND	DB	TK	Clamping bolts	ID
mm	mm	mm	mm	mm	mm	mm	mm	PCS	
80	35 DKN	15.5	15.5	72	47.5	170	130	4	<b>150001 ●</b>
80	40 DKN	15.5	15.5	72	47.5	170	130	4	<b>150008 ●</b>

**Spare parts:**

Machine	BEZ	ID	ID
		LH	RH
Homag	Securing part	<b>066460 ●</b>	<b>066461 ●</b>
IMA	Securing part	<b>066556 ●</b>	<b>066556 ●</b>
	Hexagon key		<b>117516 ●</b>

Spindle securing part consists of:

Conical spring washer, clamping nut or clamping screw, spanner or hexagon spanner, brace.

**Application:**

Spacer for flush mounting when using cutter flange type 160/2, type 160/3.

**Quick clamping sleeve**

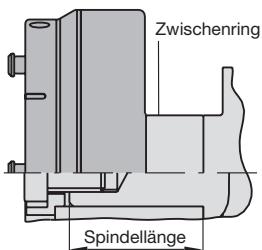

Quick clamping sleeve, flush mounted on spindle

**Spacer / set for flush mounting**

AT 100 0

Machine	Type	ABM	ABM-spindle	ID
		mm	mm	
IMA	160/2 - 3	60x15/20x35.DKN	35 DKNx93	<b>028803 ●</b>
Homag	160/2 - 3	60x10/20x35.DKN	35 DKNx70	<b>028804 ●</b>

## 7. Clamping systems

### 7.2 Quick clamping elements

#### 7.2.2 Mechanical clamping

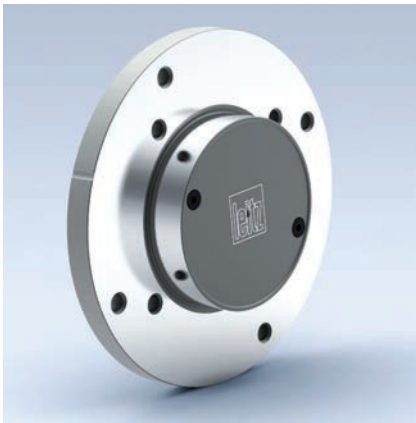

### Spindle with safety device against twisting - keyway tool flange type 160

**Application:**

Tool flange for quick clamping sleeve type 160. Hardened steel tool body for quick clamping of tools and hoggers.

**Machine:**

Double-end tenoners, finger joint machines, edgebanding machines etc.

**Technical information:**

Tool mounted directly on the flange. RPM  $n_{max}$  9000 min<sup>-1</sup>.

**Attention:** Comply with maximum admissible speed for the mounted tools!

**Tool flange**

TD 882 0 01, TD 883 0 01

Tool Type	ID	ID
	LH	RH
160/1 for cutting tools BO 30 mm/NL 17.7	<b>159059</b>	<b>159060</b>
160/2 for hoggers BO 80 mm/NL 17.7	<b>159063</b> ●	<b>159064</b> ●

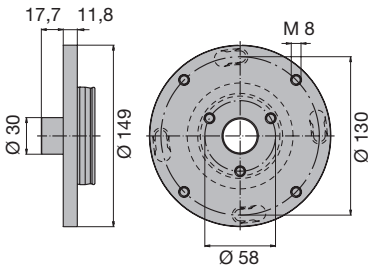

Tool flange type 160/1, for tools

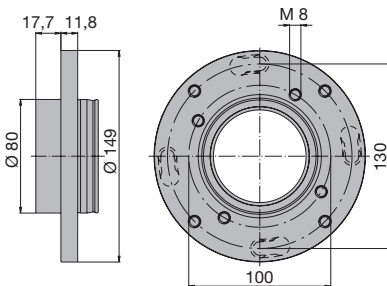

Tool flange type 160/2, for hoggers

## 7. Clamping systems

### 7.3 Clamping chucks 7.3.1 Shrink-fit chucks

#### Application

Clamping of shank tools with high precision and stability.

#### Machine

Stationary routers with/without CNC control and cutter spindles for automatic tool change.  
Milling machines with cutter spindles for automatic tool change.

#### Technical features

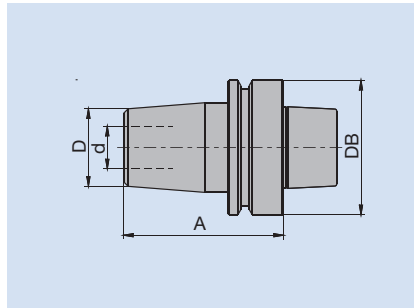

Shrink-fit chuck with hollow taper shank.

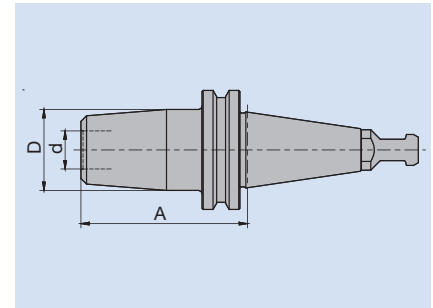

Shrink-fit chuck with steep taper.

D	Largest diameter of the chuck in the clamping area
d	Clamping or bore diameter
DB	Outer diameter of groove
A	Length from reference point on steep taper or HSK reference surface

#### Permissible shank tolerances

Tools clamped in shrink-fit chucks must have at least the following tool shank tolerances:

Tools mounted in Shrink-fit chucks	Diameter of shank	
	< 12 mm	≥ 12 mm
	ISO h6	ISO g6

#### Application data

##### Maximum RPM

The maximum RPM for shrink-fit chucks:  $n_{\max} = 36000 \text{ min}^{-1}$ .

#### Operation

Shrink-fit chucks have a bore smaller than the diameter of the shank to be clamped. The chuck is opened by heating the chuck in the clamping area. The HF generator, enables quick and secure expansion of the shrink-fit chucks by induction heating allowing.

The tool can be fitted / replaced. After the chuck has cooled down the tool is ready for use.

After short, quick heating the tool can be removed or fitted. After the chuck has cooled down the tool can be used.



Leitz High Frequency Generator ISG3400.



### Shrink-fit chuck ThermoGrip® Tapered

#### Application:

High precision tool chuck for clamping shank tools by thermal shrinking. Has the highest stability and rigidity of all known shank tools clamping systems, suitable for HSC and HPC machining.

#### Technical information:

Tool chuck for high performance. Precision-balanced for speeds up to 36000 min<sup>-1</sup>. Short, slim design for improved chip flow extraction. For clamping tungsten carbide and steel shanks. Clamping eccentricity  $e \leq 0.01$  mm. Integrated length adjustment to adopt the clamping depth of the tool.

#### SK 30, DIN ISO 7388

PT 301 0

Type	d	D	DB	A	GL	Weight	Length adj.	STO	ID
	mm	mm	mm	mm	mm	kg	mm		
A	12	34	50	70	141.8	0.7	7	g6	670200 <input type="checkbox"/>
A	16	34	50	70	141.8	0.7	7	g6	670201 <input type="checkbox"/>
A	20	42	50	70	141.8	0.8	7	g6	670202 <input type="checkbox"/>
A	25	42	50	80	151.8	1.0	7	g6	670210 <input type="checkbox"/>
B	12	34	50	70	141.8	0.7	7	g6	670203 <input type="checkbox"/>
B	16	34	50	70	141.8	0.7	7	g6	670204 <input type="checkbox"/>
B	20	42	50	70	141.8	0.8	7	g6	670205 <input type="checkbox"/>
B	25	42	50	80	151.8	1.0	7	g6	670211 <input type="checkbox"/>

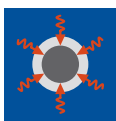

Comparison of transferable torque of traditional clamping chucks

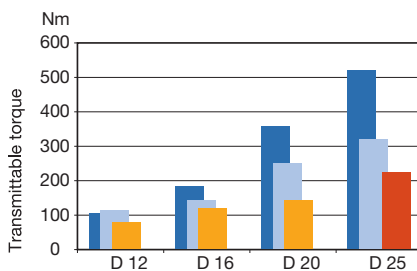

■ ThermoGrip® shrink-fit chuck

■ Collet DIN ISO 10897-B25, 75 Nm Tightening torque

■ Collet DIN ISO 15488-B32 (ER32), 75 Nm Tightening torque

■ Hydro clamping chuck

The clamping range of collet chucks and hydro clamping chucks includes shank tolerances g7 and h6. Leitz ThermoGrip® chucks are designed for a shank tolerance h6 for clamping diameters  $d < 12$  mm and a shank tolerance g6 for clamping diameters  $d \geq 12$  mm.

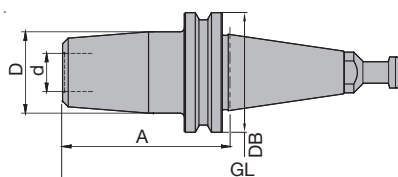

#### SK 40, DIN ISO 7388

PT 301 0

Type	d	D	DB	A	GL	Weight	Length adj.	STO	ID
	mm	mm	mm	mm	mm	kg	mm		
E	12	34	63.5	70	164.4	1.1	7	g6	670206 <input type="checkbox"/>
E	16	34	63.5	70	164.4	1.1	7	g6	670207 <input type="checkbox"/>
E	20	42	63.5	70	164.4	1.2	7	g6	670208 <input type="checkbox"/>
E	25	42	63.5	80	174.4	1.2	7	g6	670209 <input type="checkbox"/>

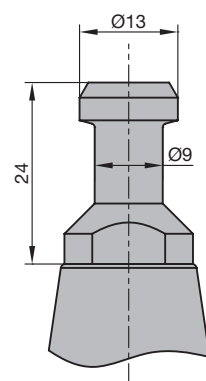

Type: A  
SK 30 pull stud as per DIN ISO 7388

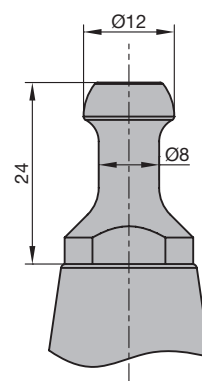

Type: B  
SK 30/ISO 30 pull stud for HSD spindles from construction year 9/92 on

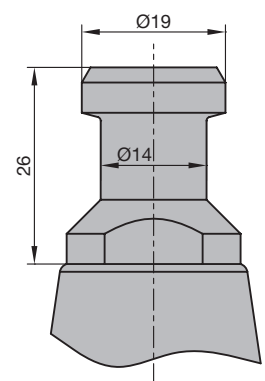

Type: E  
SK 40 pull stud as per DIN ISO 7388

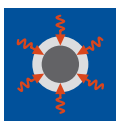

Comparison of transferable torque of traditional clamping chucks

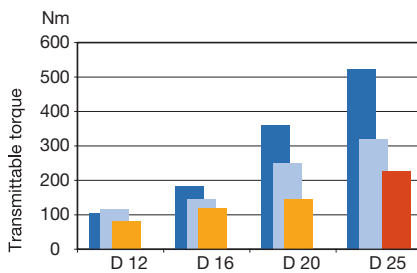

- ThermoGrip® shrink-fit chuck
- Collet DIN ISO 10897-B25, 75 Nm Tightening torque
- Collet DIN ISO 15488-B32 (ER32), 75 Nm Tightening torque
- Hydro clamping chuck

The clamping range of collet chucks and hydro clamping chucks includes shank tolerances g7 and h6. Leitz ThermoGrip® chucks are designed for a shank tolerance h6 for clamping diameters  $d < 12$  mm and a shank tolerance g6 for clamping diameters  $d \geq 12$  mm.

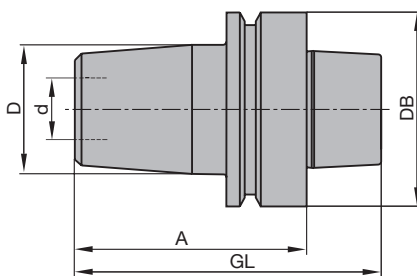

### Shrink-fit chuck ThermoGrip® with hollow taper shank

#### Application:

High precision tool chuck for clamping shank tools by thermal shrinking. Has the highest stability and rigidity of all known shank tools clamping systems, suitable for HSC and HPC machining.

#### Technical information:

Tool chuck for high performance. Precision-balanced for speeds up to 36000 min<sup>-1</sup>. Short, slim design for improved chip flow extraction. For clamping tungsten carbide and steel shanks. Clamping eccentricity  $e \leq 0.01$  mm.

#### HSK-E 63, DIN 69893

PT 300 0

d mm	D mm	DB mm	A mm	GL mm	Weight kg	STO	ID without chip
8	27	63	75	107	0.9	h6	670002 ●
9.53	34	63	75	107	0.9	h6	670023 ●
10	32	63	75	107	0.9	h6	670003 ●
12	34	63	75	107	0.9	g6	670004 ●
12.7	34	63	75	107	0.9	h6	670024 ●
14	34	63	75	107	0.9	g6	670005 ●
16	34	63	75	107	0.9	g6	670006 ●
18	42	63	75	107	1.0	g6	670007 ●
20	42	63	75	107	1.0	g6	670008 ●
25	42	63	75	107	1.0	g6	670009 ●
32	53	63	90	122	1.2	g6	670016 ●

#### HSK-F 63, DIN 69893

PT 300 0

d mm	d in	D mm	DB mm	A mm	GL mm	Weight kg	STO	ID With chip	ID Without chip
6		27	63	75	100	0.8	h6	037753 □	037713 ●
8		27	63	75	100	0.8	h6	037754 □	037714 ●
9.53	3/8"	32	63	75	100	0.9	h6	670013 □	670010 ●
10		32	63	75	100	0.9	h6	037755 □	037715 ●
10		32	63	120	145	1.0	h6		670017 ●
12		34	63	75	100	0.9	g6	037752 □	037712 ●
12		34	63	90	115	1.0	g6		670018 ●
12		34	63	120	145	1.1	g6		670019 ●
12.7	1/2"	34	63	75	100	0.9	h6	670014 □	670011 ●
14		34	63	75	100	0.9	g6	037756 □	037716 ●
16		34	63	75	100	0.9	g6	037719 □	037709 ●
16		34	63	95	120	1.0	g6		670020 ●
16		34	63	120	145	1.0	g6		670021 ●
18		42	63	75	100	1.0	g6	037757 □	037718 ●
19.05	3/4"	42	63	75	100	0.9	h6	670015 □	670012 ●
20		42	63	75	100	1.0	g6	037750 □	037710 ●
20		42	63	100	125	1.2	g6		670022 ●
25		42	63	75	100	0.9	g6	037751 □	037711 ●
32		53	63	90	115	1.2	g6	670001 □	670000 ●

#### Note:

Chucks with chip already have a data chip (511 bytes) ID **081309** ex works. Chips with larger capacity are available on request.

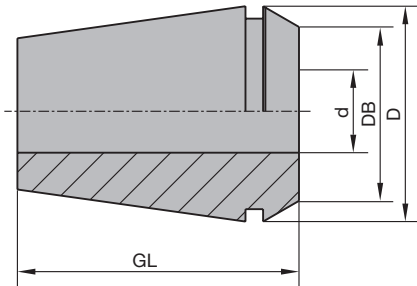
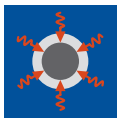

Shrink-fit collet TER, TB 120 0 01

**Note:**

Corresponding accessories for shrink-fit units are required in order to use shrink-fit collets TER - ER together with the shrink-fit units ISG 22xx / 32xx or 24xx / 34xx.  
See: Brochure ThermoGrip® shrink-fit generator.

### Shrink collet ThermoGrip®, Type TER, DIN ISO 15488

**Application:**

High precision tool chuck for clamping shank tools by thermal shrinking. Has the highest stability and rigidity of all known shank tools clamping systems, suitable for HSC and HPC machining.

**Technical information:**

Replacement for conventional spring collets to increase concentricity, rigidity and speed strength. Universal design for the adaptation of shank tools in machining aggregates as well as direct clamping in spindles with integrated collet adaptor. For clamping of carbide and steel shanks. Clamping eccentricity  $e \leq 0.01$  mm.

**Attention:** In order to mount the collet nut in the shrunk tool, the tool diameter is not allowed to be larger than the collar diameter (DB) stated in the table. In individual cases the existing clamping nut must be exchanged with the version stated in the table.

**TER - ER16, DIN ISO 15488, 8°**

TB 120 0 01

BEZ	d mm	D mm	DB mm	GL mm	ID
Shrink collet	3	17	12	27	679500 <input type="checkbox"/>
Shrink collet	4	17	12	27	679501 <input type="checkbox"/>
Shrink collet	6	17	12	27	679502 <input type="checkbox"/>
Shrink collet	8	17	12	27	679503 <input type="checkbox"/>

**Spare parts:**

BEZ	ABM mm	D mm	ID
Collet chuck nut	M22x1.5	28	006657 <input type="checkbox"/>

**TER - ER20, DIN ISO 15488, 8°**

TB 120 0 01

BEZ	d mm	D mm	DB mm	GL mm	ID
Shrink collet	6	21	15.5	31	679504 <input type="checkbox"/>
Shrink collet	8	21	15.5	31	679505 <input type="checkbox"/>
Shrink collet	10	21	15.5	31	679506 <input type="checkbox"/>

**Spare parts:**

BEZ	ABM mm	D mm	ID
Collet chuck nut	M25x1,5	34	006658 <input type="checkbox"/>

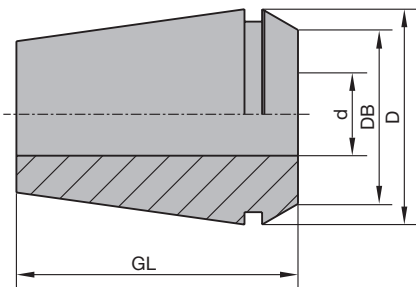
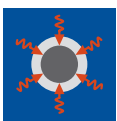

Shrink-fit collet TER, TB 120 0 01

**Note:**

Corresponding accessories for shrink-fit units are required in order to use shrink-fit collets TER - ER together with the shrink-fit units ISG 22xx / 32xx or 24xx / 34xx.  
See: Brochure ThermoGrip® shrink-fit generator.

### Shrink collet ThermoGrip®, Type TER, DIN ISO 15488

**Application:**

High precision tool chuck for clamping shank tools by thermal shrinking. Has the highest stability and rigidity of all known shank tools clamping systems, suitable for HSC and HPC machining.

**Technical information:**

Replacement for conventional spring collets to increase concentricity, rigidity and speed strength. Universal design for the adaptation of shank tools in machining aggregates as well as direct clamping in spindles with integrated collet adaptor. For clamping of carbide and steel shanks. Clamping eccentricity  $e \leq 0.01$  mm.

**Attention:** In order to mount the collet nut in the shrunk tool, the tool diameter is not allowed to be larger than the collar diameter (DB) stated in the table. In individual cases the existing clamping nut must be exchanged with the version stated in the table.

**TER - ER25, DIN ISO 15488, 8°**

TB 120 0 01

BEZ	d mm	D mm	DB mm	GL mm	ID
Shrink collet	3	26	20.5	35	<b>679507</b> □
Shrink collet	4	26	20.5	35	<b>679508</b> □
Shrink collet	6	26	20.5	35	<b>679509</b> □
Shrink collet	8	26	20.5	35	<b>679510</b> □
Shrink collet	10	26	20.5	35	<b>679511</b> □
Shrink collet	12	26	20.5	35	<b>679512</b> □
Shrink collet	14	26	20.5	35	<b>679513</b> □
Shrink collet	16	26	20.5	35	<b>679514</b> □

**Spare parts:**

BEZ	ABM mm	D mm	ID
Collet chuck nut	M32x1,5	42	<b>006659</b> □

**TER - ER32, DIN ISO 15488, 8°**

TB 120 0 01

BEZ	d mm	D mm	DB mm	GL mm	ID
Shrink collet	6	33	26.5	40	<b>679515</b> □
Shrink collet	8	33	26.5	40	<b>679516</b> □
Shrink collet	10	33	26.5	40	<b>679517</b> □
Shrink collet	12	33	26.5	40	<b>679518</b> □
Shrink collet	14	33	26.5	40	<b>679519</b> □
Shrink collet	16	33	26.5	40	<b>679520</b> □
Shrink collet	18	33	26.5	40	<b>679521</b> □
Shrink collet	20	33	26.5	40	<b>679522</b> □

**Spare parts:**

BEZ	ABM mm	D mm	ID
Collet chuck nut	M40x1,5	50	<b>006660</b> □



## 7. Clamping systems

### 7.3 Clamping chucks

#### 7.3.2 Hydro chucks

<b>Application</b>	High precision clamping of shank tools.								
<b>Machine</b>	Stationary routers with CNC control and spindles for automatic tool change. Milling machines with spindles for automatic tool change.								
<b>Technical features</b>	Hydro chucks are used to clamp shank tools in spindles with high precision. Hydro chucks have the same concentric run out tolerance as shrink-fit chucks, but shrink-fit chucks have considerably higher stability. Shrink-fit chucks are recommended for high cutting forces machining operations.								
<b>Permissible shank tolerances</b>	Tools clamped in hydro chucks must have the following tool shank tolerances: <table border="1" style="width: 100%; border-collapse: collapse;"> <thead> <tr> <th rowspan="2">Tools mounted in Hydro chucks</th> <th colspan="2">Diameter of shank</th> </tr> <tr> <th>&lt; 12 mm</th> <th>≥ 12 mm</th> </tr> </thead> <tbody> <tr> <td></td> <td>ISO h6</td> <td>ISO g6</td> </tr> </tbody> </table>	Tools mounted in Hydro chucks	Diameter of shank		< 12 mm	≥ 12 mm		ISO h6	ISO g6
Tools mounted in Hydro chucks	Diameter of shank								
	< 12 mm	≥ 12 mm							
	ISO h6	ISO g6							
<b>Application data</b>	<b>Maximum RPM</b> Maximum RPM for hydro chucks: $n_{\max} = 25000 \text{ min}^{-1}$ .								
<b>Reducing the clamping diameter</b>	The standard clamping diameter for Leitz hydro chucks is 25 mm. Other shank diameters are clamped using reducing sleeves. The use of reducing sleeves significantly decreases the clamping force and the concentric run out tolerance. It is recommended not to reduce the shank diameter except when absolutely necessary.								

The following shank diameters can be clamped with reducing sleeves:

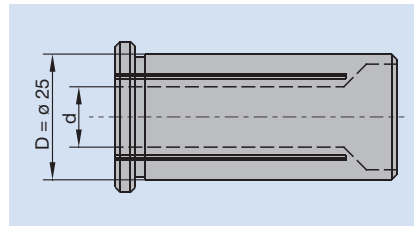

D	25 mm
d	12 mm
	14 mm
	16 mm
	20 mm



**Hydro chucks for shank tools with hollow shank taper HSK-F 63**

**Application:**

High precision tool chuck for hydro clamping shank tools with cylindrical shank and shank diameters up to  $d_{max} = 25$  mm.

**Technical information:**

Reduction of clamping diameter by special reduction inserts. Independent of direction of rotation, suitable for right hand and left hand rotation tool. Easy handling clamping system. Tool adaptor finely balanced. Maximum admissible speed  $n_{max} = 25000 \text{ min}^{-1}$ .

**Clamping diameter 25 mm**

PH 350 0

d	D	DB	A	GL	Weight	ID
mm	mm	mm	mm	mm	kg	
25	50	63	85	100	1.1	<b>039086 ●</b>



Sales unit consisting of chuck and clamping key.

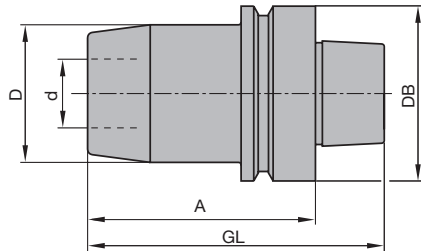

Hydro chuck HSK-F 63

**Spare parts:**

BEZ	ABM	ID
	mm	
Reducing sleeve	d12/25x56x12	<b>039081 ●</b>
Reducing sleeve	d14/25x56x14	<b>039082 ●</b>
Reducing sleeve	d16/25x56x16	<b>039083 ●</b>
Reducing sleeve	d20/25x56x20	<b>039084 ●</b>
Allen key	SW 5	<b>005446 ●</b>

## 7. Clamping systems

### 7.3 Clamping chucks

#### 7.3.3 Collet chucks

**Application** Clamping system for shank tools.

**Machine** Stationary routers with/without CNC control, CNC machining centres  
Milling machines with spindles to mount shank tools,  
Router machines without automatic tool change,  
Portable routers.

**Technical features**

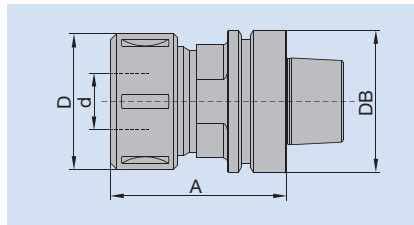

Collet chuck HSK-F 63.

D	Largest diameter of the chuck in the clamping area
d	Tool shank clamping diameter
DB	Diameter of chuck face
A	Length to reference point (SK) or to reference surface (HSK)

**Permissible shank tolerances** Tools clamped in collet chucks must have at least the following tool shank tolerances:

Tools mounted in Collet chuck	Diameter of shank	
	< 12 mm	≥ 12 mm
	ISO g7	ISO g7

**Collet nut clamping torque** The following torques are required for safe clamping of the tool in the collet chuck:

Collet nut thread	Spanner type	Clamping torque
M 30 x 1,5	SW 40/42	60 Nm
M 33 x 1,5	SW 40/42	60 Nm
M 40 x 1,5	SW 45/50	80 Nm
M 48 x 2	SW 58/62	100 Nm
M 50 x 1,5	SW 58/62	100 Nm

**Application data**

**Maximum RPM**

The maximum RPM for collet chucks:

$n_{max} = 24000 \text{ min}^{-1}$  (shank diameters up to 25 mm).

HSC Collet chucks (High Speed Cutting) have a maximum RPM:  $n_{max} = 30000 \text{ min}^{-1}$ .

**Collet chuck design**

Leitz collet chucks are available for the two designs of collet below.

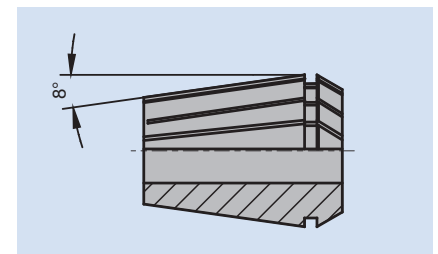
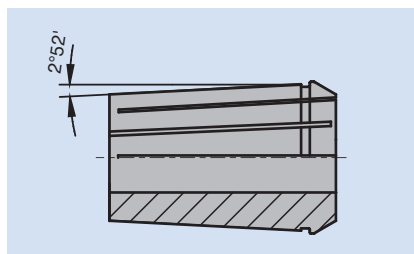

Collet taper angle 2°52': DIN ISO 10897.

Collet taper angle 8°: DIN ISO 15488.

Collets with a taper angle of 2°52', taper tolerance 1:10, DIN ISO 10897 are recommended.



#### Precision collet chuck, cylindrical shank

##### Application:

Precision tool chuck with collet for clamping shank tools with cylindrical shank and shank diameters up to  $d_{max} = 16$  mm.

##### Technical information:

Exact concentricity through hardened, ground and double slotted collets. Easy handling as loosening the ball bearing collet nut automatically opens the collet. Suitable for right and left hand rotation because of ball bearing collet nut. Ball bearing collet nut for increased clamping forces and improved concentricity compared to monobloc design.

##### Model with ball bearing collet nut

PM 350 0 03

d	D	A	GL	S	Weight	Type	ID
mm	mm	mm	mm	mm	kg		
6 - 12.7	35		77	25x50	0.6	1	<b>671001</b> ●
6 - 16	43	55	115	MK II / M30	0.8	2	<b>037493</b> ●
6 - 16	43		108	25x60	0.8	2	<b>037494</b> ●

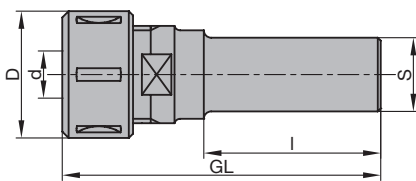

Collet chuck with cylindrical shank

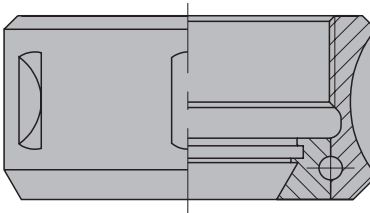

Ball bearing collet nut

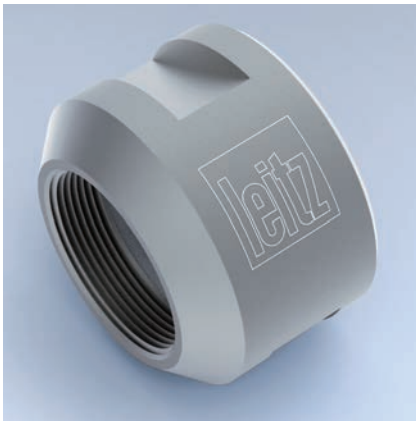

Sales unit consists of clamping chuck, collet nut and key, without collet.

##### Spare parts:

BEZ	ABM	for S	ID	ID
	mm	mm	1	2
Collet (2°52')		6	<b>679013</b> ●	<b>679005</b> ●
Collet (2°52')		7	<b>679015</b> ●	
Collet (2°52')		8	<b>679016</b> ●	<b>679032</b> ●
Collet (2°52')		9	<b>679017</b> ●	<b>679033</b> ●
Collet (2°52')		9.5		<b>679034</b> ●
Collet (2°52')		10	<b>679019</b> ●	<b>679006</b> ●
Collet (2°52')		11		<b>679035</b> ●
Collet (2°52')		12	<b>679020</b> ●	<b>679036</b> ●
Collet (2°52')		13		<b>679007</b> ●
Collet (2°52')		14		<b>679037</b> ●
Collet (2°52')		16		<b>679008</b> ●
Collet (2°52')		6.35 (1/4")	<b>679014</b> ●	<b>679009</b> ●
Collet (2°52')		9.53 (3/8")	<b>679018</b> ●	<b>679010</b> ●
Collet (2°52')		12.7 (1/2")	<b>679021</b> ●	<b>679011</b> ●
Sickle spanner	34/36		<b>005498</b> ●	
Sickle spanner	40/42			<b>005469</b> ●
Collet chuck nut	M27x1.5		<b>006653</b> ●	
Collet chuck nut with ball bearing	M33x1.5			<b>005685</b> ●

#### Clamping nut for morse taper II shanks

##### Application:

For clamping tools or tool chucks with morse taper II shanks (MK II).

##### Technical information:

$d_1 = W 1 1/8''$  suitable for Perske and Maka motor spindles.

$d_1 = M 33 X 3$  suitable for Italian routers.

##### With differential thread

TK 510 0

D	$d_1$	$d_2$	GL	ID
mm	mm	mm	mm	RH
45	W 1 1/8"	M30x1,5	30	<b>005682</b> ●
45	M33x3	M30x1,5	35	<b>006624</b> ●

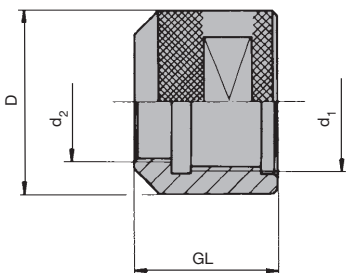

Fixing nut TK 510 0  
 $d_1$  = machine related  
 $d_2$  = tool related



### Collet chuck with steep taper for CNC aggregates

#### Application:

Precision tool chuck with collet for clamping shank tools with cylindrical shank and shank diameters up to  $d_{\max} = 16 \text{ mm}$  (5/8").

#### Technical information:

Steep taper design for Flex 5+ aggregates (Homag Group) and 5-motion-Plus aggregate (Felder Format-4). Exact concentric running through hardened, ground and double slotted collets. Easy handling through automatic opening of the collet when opening the collet nut. Tool adaptor and collet nut fine balanced. Maximum tool protrusion of the chuck = 50 mm. A collet with clamping diameter 10 mm is included.

#### A = 30 mm, diameter range 3-16 mm

PM 350 0

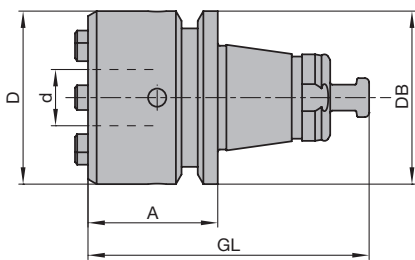

Collet chuck

Machine	d mm	D mm	DB mm	A mm	GL mm	Weight kg	ID
Felder Format-4, Homag Group	3 - 16	40	40	30	65	0.3	<b>672002 ●</b>

#### Spare parts:

BEZ	ABM mm	for S mm	ID
Collet (8°)		6	<b>037979 ●</b>
Collet (8°)		8	<b>037980 ●</b>
Collet (8°)		10	<b>037981 ●</b>
Collet (8°)		12	<b>037982 ●</b>
Collet (8°)		14	<b>037983 ●</b>
Collet (8°)		16	<b>037984 ●</b>
Collet (8°)		6.35 (1/4")	<b>679027 ●</b>
Collet (8°)		9.53 (3/8")	<b>679028 ●</b>
Collet (8°)		12.7 (1/2")	<b>679029 ●</b>
Collet (8°)		15.88 (5/8")	<b>679030 ●</b>
Clamping key	E25AX		<b>117519 ●</b>
Collet chuck nut	ERAX25		<b>116501 □</b>



#### Collet chuck with steep taper SK 30

##### Application:

Precision tool chuck with collet for clamping shank tools with cylindrical shank and shank diameters up to  $d_{max} = 20$  mm.

##### Technical information:

Steep taper design as per DIN ISO 7388, without grooves and notches. Exact concentric running through hardened, ground and double slotted collets. Vibration free cutting by short design. Easy handling through automatic opening of the collet when loosening the collet nut. Suitable for right hand and left hand rotation due to ball bearing collet nut. Ball bearing collet nut for increased clamping forces and improved concentricity compared to monobloc design. Tool chuck and collet nut fine balanced. Suitable mounting device VN 799 0 see section Knives and Spare Parts.

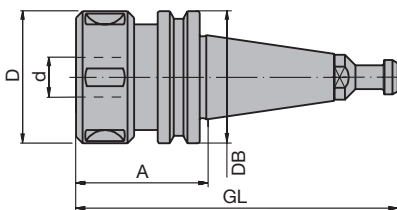

**SK 30, A = 50 / 63 mm, diameter range 6-20 mm, 8° taper angle of the collet**  
PM 350 0 04

Type	d mm	D mm	DB mm	A mm	GL mm	Weight kg	ID
B	6 - 20	50	50	50	121.8	0.6	037904 ●
B	6 - 20	50	50	63	134.8	0.7	672001 ●

Sales unit consisting of clamping chuck with ball bearing collet nut, without collet or spanner.

Collet chuck with steep taper

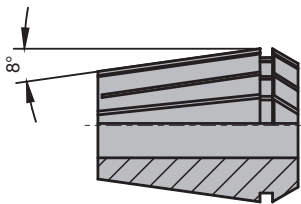

Collet angle 8°: DIN ISO 15488

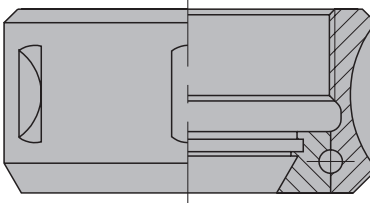

Ball bearing collet nut

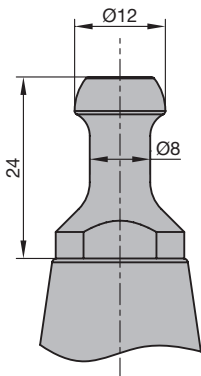

Type: B  
SK 30/ISO 30 pull stud for HSD spindles  
from construction year 9/92 on

##### Spare parts:

BEZ	ABM mm	for S mm	ID
Collet (8°)		6	037439 ●
Collet (8°)		8	037440 ●
Collet (8°)		10	037441 ●
Collet (8°)		12	037442 ●
Collet (8°)		13	037443 ●
Collet (8°)		14	037444 ●
Collet (8°)		16	037445 ●
Collet (8°)		18	037446 ●
Collet (8°)		20	037447 ●
Collet (8°)		6.35 (1/4")	037509 ●
Collet (8°)		9.53 (3/8")	037510 ●
Collet (8°)		12.7 (1/2")	037511 ●
Collet (8°)		15.88 (5/8")	037507 ●
Collet (8°)		19.05 (3/4")	037506 ●
Sickle spanner	45/50		005491 ●
Collet chuck nut with ball bearing	M40x1.5		005718 ●



#### Collet chuck with steep taper SK 30

##### Application:

Precision tool chuck with collet for clamping shank tools with cylindrical shank and shank diameters up to  $d_{max} = 25.4$  mm (1").

##### Technical information:

Steep taper design as per DIN ISO 7388, without grooves and notches. Exact concentric running through hardened, ground and double slotted collets. Easy handling as loosening the ball bearing collet nut automatically opens the collet. Suitable for right hand and left hand rotation because of ball bearing collet nut. Ball bearing collet nut for increased clamping forces and improved concentricity compared to monobloc design. Tool chuck and collet nut fine balanced. Suitable mounting device VN 799 0 see section Knives and Spare Parts.

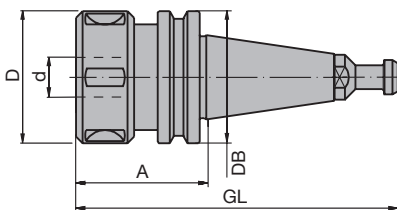

#### SK 30, A = 61 mm, 8° taper angle of collet, diameter range 6-25.4 mm

PM 350 0 16

Type	d mm	D mm	DB mm	A mm	GL mm	Weight kg	ID
B	6 - 25.4	63	50	61	108.8	0.9	<b>037968 ●</b>

Sales unit consisting of clamping chuck with ball bearing collet nut, without collet or spanner.

Collet chuck with steep taper

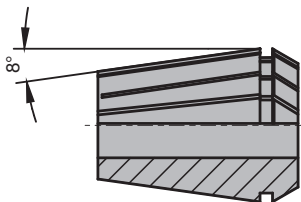

Collet angle 8°: DIN ISO 15488

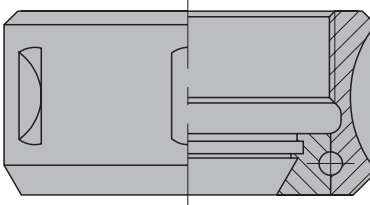

Ball bearing collet nut

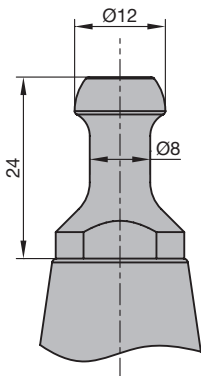

Type: B

SK 30/ISO 30 pull stud for HSD spindles  
from construction year 9/92 on

##### Spare parts:

BEZ	ABM mm	for S mm	ID
Collet (8°)		6	<b>037926 ●</b>
Collet (8°)		8	<b>037927 ●</b>
Collet (8°)		10	<b>037928 ●</b>
Collet (8°)		12	<b>037929 ●</b>
Collet (8°)		14	<b>037930 ●</b>
Collet (8°)		16	<b>037931 ●</b>
Collet (8°)		20	<b>037932 ●</b>
Collet (8°)		25	<b>037933 ●</b>
Collet (8°)		6.35 (1/4")	<b>037934 ●</b>
Collet (8°)		9.53 (3/8")	<b>037935 ●</b>
Collet (8°)		12.7 (1/2")	<b>037936 ●</b>
Collet (8°)		15.88 (5/8")	<b>037937 ●</b>
Collet (8°)		19.05 (3/4")	<b>037938 ●</b>
Collet (8°)		25.4 (1")	<b>037939 ●</b>
Sickle spanner	58/62		<b>005458 ●</b>
Collet chuck nut with ball bearing	M50x1.5		<b>006639 ●</b>



#### Collet chuck with steep taper SK 30 / SK 40

##### Application:

Precision tool chuck with collet for clamping shank tools with cylindrical shank and shank diameters up to  $d_{max} = 25.4 \text{ mm}$  (1").

##### Technical information:

Steep taper design as per DIN ISO 7388, without grooves and notches. Exact concentric running through hardened, ground and double slotted collets. Easy handling as loosening the ball bearing collet nut automatically opens the collet. Suitable for right hand and left hand rotation because of ball bearing collet nut. Ball bearing collet nut for increased clamping forces and improved concentricity compared to monobloc design. Tool chuck and collet nut fine balanced. Suitable mounting device VN 799 0 see section Knives and Spare Parts.

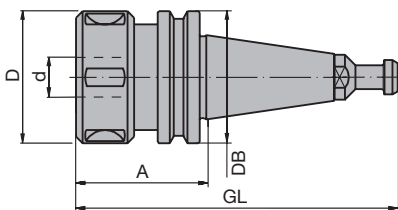

##### SK 30, A = 70 mm, diameter range 6-25.4 mm

PM 350 0 05

Type	d mm	D mm	DB mm	A mm	GL mm	Weight kg	ID
A	6 - 25.4	60	50	70	141.8	0.9	<b>037421 ●</b>

##### SK 40, A = 70 mm, diameter range 6-25.4 mm

PM 350 0 05

Type	d mm	D mm	DB mm	A mm	GL mm	Weight kg	ID
E	6 - 25.4	60	63.55	70	164.6	1.5	<b>037422 ●</b>

Collet chuck with steep taper

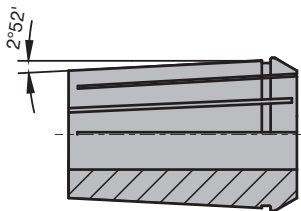

Collet angle 2°52': DIN ISO 10897

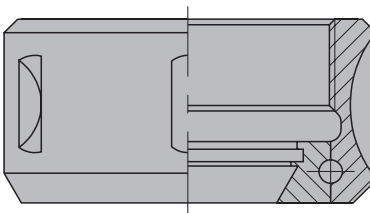

Ball bearing collet nut

Sales unit consisting of clamping chuck with ball bearing collet nut, without collet or spanner.

##### Spare parts:

BEZ	ABM mm	for S mm	ID
Collet (2°52')		6	<b>037429 ●</b>
Collet (2°52')		8	<b>037430 ●</b>
Collet (2°52')		10	<b>037431 ●</b>
Collet (2°52')		12	<b>037432 ●</b>
Collet (2°52')		13	<b>037433 ●</b>
Collet (2°52')		14	<b>037434 ●</b>
Collet (2°52')		16	<b>037435 ●</b>
Collet (2°52')		18	<b>037436 ●</b>
Collet (2°52')		20	<b>037437 ●</b>
Collet (2°52')		25	<b>037438 ●</b>
Collet (2°52')		6.35 (1/4")	<b>037495 ●</b>
Collet (2°52')		9.53 (3/8")	<b>037505 ●</b>
Collet (2°52')		12.7 (1/2")	<b>037496 ●</b>
Collet (2°52')		15.88 (5/8")	<b>037502 ●</b>
Collet (2°52')		19.05 (3/4")	<b>037497 ●</b>
Collet (2°52')		25.4 (1")	<b>037508 ●</b>
Sickle spanner	58/62		<b>005458 ●</b>
Collet chuck nut with ball bearing	M48x2		<b>005714 ●</b>
Locking nut with Euchner chip	SK 40, 511 Bytes		<b>081600 ●</b>
Locking nut with Balluff chip	SK 40, 511 Bytes		<b>081601 ●</b>

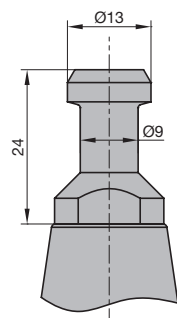

Type: A  
SK 30 pull stud as per  
DIN ISO 7388

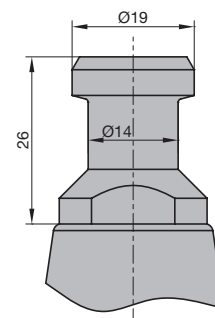

Type: E  
SK 40 pull stud as per  
DIN ISO 7388





#### Collet chuck with steep taper BT 30 and BT 35

##### Application:

Precision tool chuck with collet for clamping shank tools with cylindrical shank and shank diameters up to  $d_{max} = 25.4$  mm (1").

##### Technical information:

Steep taper design BT 30 or BT 35. Exact concentric running through hardened, ground and double slotted collets. Easy handling as loosening the ball bearing collet nut automatically opens the collet. Suitable for right hand and left hand rotation because of ball bearing collet nut. Ball bearing collet nut for increased clamping forces and improved concentricity compared to monobloc design. Tool chuck and collet nut fine balanced. Suitable mounting device VN 799 0 see section Knives and Spare Parts. (Design for SK 30).

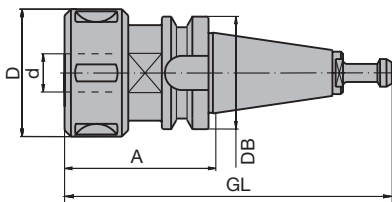

Collet chuck BT 35

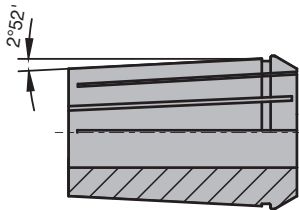

Collet angle 2°52': DIN ISO 10897

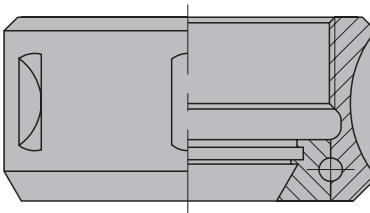

Ball bearing collet nut

##### Steep taper BT 30 without grooves and notches

PM 350 0 07

Type	d mm	D mm	DB mm	A mm	GL mm	Weight kg	ID
F	6 - 25.4	60	46	70	141.4	0.9	<b>037962 ●</b>

##### Steep taper BT 35 with grooves and notches

PM 350 0 07

Type	d mm	D mm	DB mm	A mm	GL mm	Weight kg	ID
G	6 - 25.4	60	53	70	154.4	1	<b>037414 ●</b>

Sales unit consisting of clamping chuck with ball bearing collet nut, without collet or spanner.

##### Spare parts:

BEZ	ABM mm	for S mm	ID
Collet (2°52')		6	<b>037429 ●</b>
Collet (2°52')		8	<b>037430 ●</b>
Collet (2°52')		10	<b>037431 ●</b>
Collet (2°52')		12	<b>037432 ●</b>
Collet (2°52')		13	<b>037433 ●</b>
Collet (2°52')		14	<b>037434 ●</b>
Collet (2°52')		16	<b>037435 ●</b>
Collet (2°52')		18	<b>037436 ●</b>
Collet (2°52')		20	<b>037437 ●</b>
Collet (2°52')		25	<b>037438 ●</b>
Collet (2°52')		6.35 (1/4")	<b>037495 ●</b>
Collet (2°52')		9.53 (3/8")	<b>037505 ●</b>
Collet (2°52')		12.7 (1/2")	<b>037496 ●</b>
Collet (2°52')		15.88 (5/8")	<b>037502 ●</b>
Collet (2°52')		19.05 (3/4")	<b>037497 ●</b>
Collet (2°52')		25.4 (1")	<b>037508 ●</b>
Sickle spanner	58/62		<b>005458 ●</b>
Collet chuck nut with ball bearing	M48x2		<b>005714 ●</b>

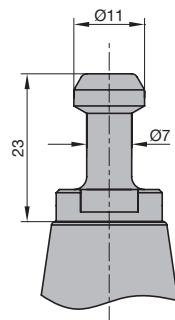

Type: F  
BT 30 pull stud  
Anderson

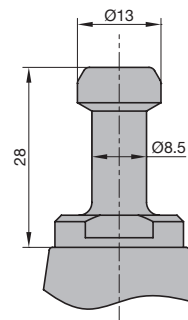

Type: G  
BT 35 pull stud  
Heian, Shoda



#### Collet chuck with hollow taper shank HSK-F 50

##### Application:

Precision tool chuck with collet for clamping shank tools with cylindrical shank and shank diameters up to  $d_{max} = 20$  mm.

##### Technical information:

Hollow taper shank as per DIN 69893. Exact concentric running through hardened, ground and double slotted collets. Easy handling as loosening the ball bearing collet nut automatically opens the collet. Suitable for right hand and left hand rotation because of ball bearing collet nut. Ball bearing collet nut for increased clamping forces and improved concentricity compared to monobloc design. Tool chuck and collet nut fine balanced. Suitable mounting device VN 799 0 see section Knives and Spare Parts.

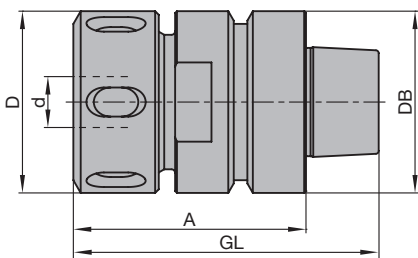

#### HSK-F 50, DIN 69893, diameter range up to 20 mm, 8° angle of the collet PM 350 0 15

d	D	DB	A	GL	Weight	ID
mm	mm	mm	mm	mm	kg	
6 - 20	50	50	64	84	0.9	<b>037999 ●</b>

Sales unit consisting of clamping chuck with ball bearing collet nut, without collet and spanner.

##### Spare parts:

BEZ	ABM	for S	ID
	mm	mm	
Collet (8°)		6	<b>037439 ●</b>
Collet (8°)		8	<b>037440 ●</b>
Collet (8°)		10	<b>037441 ●</b>
Collet (8°)		12	<b>037442 ●</b>
Collet (8°)		13	<b>037443 ●</b>
Collet (8°)		14	<b>037444 ●</b>
Collet (8°)		16	<b>037445 ●</b>
Collet (8°)		18	<b>037446 ●</b>
Collet (8°)		20	<b>037447 ●</b>
Collet (8°)		6.35 (1/4")	<b>037509 ●</b>
Collet (8°)		9.53 (3/8")	<b>037510 ●</b>
Collet (8°)		12.7 (1/2")	<b>037511 ●</b>
Collet (8°)		15.88 (5/8")	<b>037507 ●</b>
Collet (8°)		19.05 (3/4")	<b>037506 ●</b>
Sickle spanner	45/50		<b>005491 ●</b>
Collet chuck nut with ball bearing	M40x1.5		<b>005718 ●</b>

Collet chuck HSK-F 50

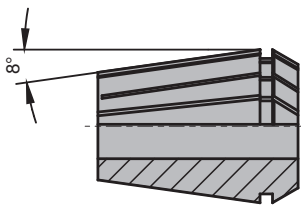

Collet angle 8°: DIN ISO 15488

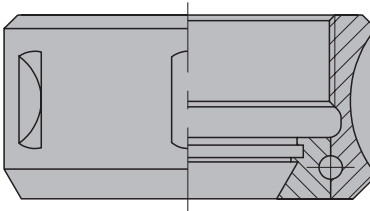

Ball bearing collet nut



#### Collet chuck with hollow taper shank HSK-F 50

##### Application:

Precision tool chuck with collet for clamping shank tools with cylindrical shank and shank diameters up to  $d_{max} = 25.4$  mm (1").

##### Technical information:

Hollow taper shank as per DIN 69893. Exact concentric running through hardened, ground and double slotted collets. Easy handling as loosening the ball bearing collet nut automatically opens the collet. Suitable for right hand and left hand rotation because of ball bearing collet nut. Ball bearing collet nut for increased clamping forces and improved concentricity compared to monobloc design. Tool chuck and collet nut fine balanced. Suitable mounting device VN 799 0 see section Knives and Spare Parts.

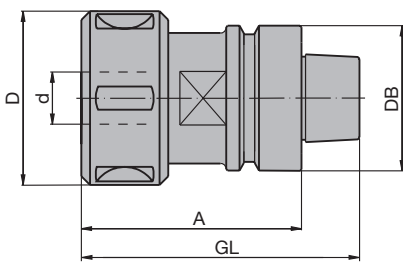

#### HSK-F 50, DIN 69893, diameter range up to 25.4 mm

PM 350 0 06

d	D	DB	A	GL	Weight	ID
mm	mm	mm	mm	mm	kg	
6 - 25.4	60	50	76	96	0.9	<b>037500 ●</b>

Sales unit consisting of clamping chuck with ball bearing collet nut, without collet or spanner.

##### Spare parts:

BEZ	ABM	for S	ID
	mm	mm	
Collet (2°52')		6	<b>037429 ●</b>
Collet (2°52')		8	<b>037430 ●</b>
Collet (2°52')		10	<b>037431 ●</b>
Collet (2°52')		12	<b>037432 ●</b>
Collet (2°52')		13	<b>037433 ●</b>
Collet (2°52')		14	<b>037434 ●</b>
Collet (2°52')		16	<b>037435 ●</b>
Collet (2°52')		18	<b>037436 ●</b>
Collet (2°52')		20	<b>037437 ●</b>
Collet (2°52')		25	<b>037438 ●</b>
Collet (2°52')		6.35 (1/4")	<b>037495 ●</b>
Collet (2°52')		9.53 (3/8")	<b>037505 ●</b>
Collet (2°52')		12.7 (1/2")	<b>037496 ●</b>
Collet (2°52')		15.88 (5/8")	<b>037502 ●</b>
Collet (2°52')		19.05 (3/4")	<b>037497 ●</b>
Collet (2°52')		25.4 (1")	<b>037508 ●</b>
Sickle spanner	58/62		<b>005458 ●</b>
Collet chuck nut with ball bearing	M48x2		<b>005714 ●</b>

Collet chuck HSK-F 50

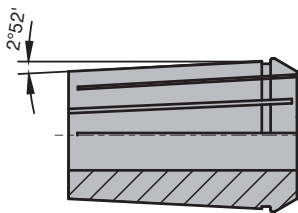

Collet angle 2°52': DIN ISO 10897

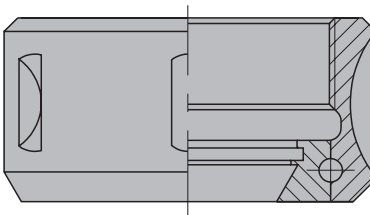

Ball bearing collet nut



#### Collet chuck with hollow taper shank HSK-E 63

##### Application:

Precision tool chuck with collet for clamping shank tools with cylindrical shank and shank diameters up to  $d_{max} = 30$  mm.

##### Technical information:

Hollow taper shank as per DIN 69893. Exact concentric running through hardened, ground and double slotted collets. Vibration free cutting by short design. Easy handling as loosening the ball bearing collet nut automatically opens the collet. Suitable for right hand and left hand rotation because of ball bearing collet nut. Ball bearing collet nut for increased clamping forces and improved concentricity compared to monobloc design. Tool chuck and collet nut fine balanced. Suitable mounting device VN 799 0 see section Knives and Spare Parts.

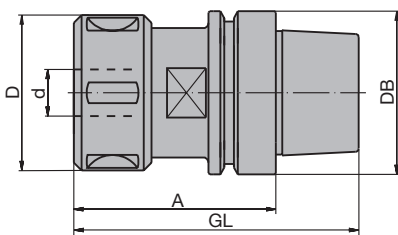

#### HSK-E 63, DIN 69893, A = 76 mm, diameter range 6-30 mm, 8° taper angle of the collet

PM 350 0 15

d	D	DB	A	GL	Weight	ID
mm	mm	mm	mm	mm	kg	
6 - 30	63	63	76	108.5	1.1	<b>679040 ●</b>

Sales unit consisting of clamping chuck with ball bearing collet nut, without collet or spanner.

Collet chuck HSK-E 63

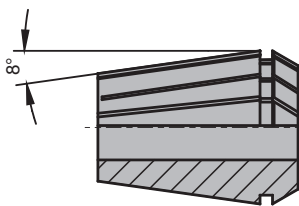

Collet angle 8°: DIN ISO 15488

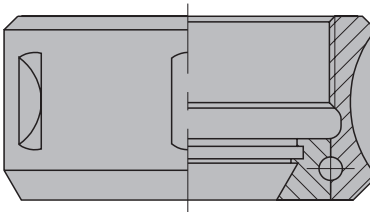

Ball bearing collet nut

##### Spare parts:

BEZ	ABM	for S	ID
	mm	mm	
Collet (8°)		6	<b>037926 ●</b>
Collet (8°)		8	<b>037927 ●</b>
Collet (8°)		10	<b>037928 ●</b>
Collet (8°)		12	<b>037929 ●</b>
Collet (8°)		14	<b>037930 ●</b>
Collet (8°)		16	<b>037931 ●</b>
Collet (8°)		20	<b>037932 ●</b>
Collet (8°)		25	<b>037933 ●</b>
Collet (8°)		30	<b>679039 ●</b>
Collet (8°)		6.35 (1/4")	<b>037934 ●</b>
Collet (8°)		9.53 (3/8")	<b>037935 ●</b>
Collet (8°)		12.7 (1/2")	<b>037936 ●</b>
Collet (8°)		15.88 (5/8")	<b>037937 ●</b>
Collet (8°)		19.05 (3/4")	<b>037938 ●</b>
Collet (8°)		25.4 (1")	<b>037939 ●</b>
Sickle spanner	58/62		<b>005458 ●</b>
Collet chuck nut with ball bearing	M50x1.5		<b>006639 ●</b>
Chip-Balluff	511 Bytes		<b>081309 ●</b>
Chip-Balluff	2047 Bytes		<b>081330 □</b>



#### Collet chuck with hollow taper shank HSK-E 63

##### Application:

Precision tool chuck with collet for clamping shank tools with cylindrical shank and shank diameters up to  $d_{max} = 25.4 \text{ mm}$  (1").

##### Technical information:

Hollow taper shank as per DIN 69893. Exact concentric running through hardened, ground and double slotted collets. Vibration free cutting by short design. Easy handling as loosening the ball bearing collet nut automatically opens the collet. Suitable for right hand and left hand rotation because of ball bearing collet nut. Ball bearing collet nut for increased clamping forces and improved concentricity compared to monobloc design. Tool chuck and collet nut fine balanced. Suitable mounting device VN 799 0 see section Knives and Spare Parts.

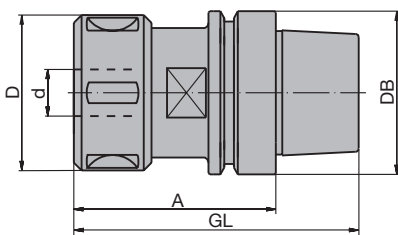

#### HSK-E 63, DIN 69893, A = 78 mm, diameter range 6-25.4 mm

PM 350 0 06

d	D	DB	A	GL	Weight	ID
mm	mm	mm	mm	mm	kg	
6 - 25.4	60	63	78	110	1.1	<b>037914 ●</b>

Sales unit consisting of clamping chuck with ball bearing collet nut, without collet or spanner.

##### Spare parts:

BEZ	ABM	for S	ID
	mm	mm	
Collet (2°52')		6	<b>037429 ●</b>
Collet (2°52')		8	<b>037430 ●</b>
Collet (2°52')		10	<b>037431 ●</b>
Collet (2°52')		12	<b>037432 ●</b>
Collet (2°52')		13	<b>037433 ●</b>
Collet (2°52')		14	<b>037434 ●</b>
Collet (2°52')		16	<b>037435 ●</b>
Collet (2°52')		18	<b>037436 ●</b>
Collet (2°52')		20	<b>037437 ●</b>
Collet (2°52')		25	<b>037438 ●</b>
Collet (2°52')		6.35 (1/4")	<b>037495 ●</b>
Collet (2°52')		9.53 (3/8")	<b>037505 ●</b>
Collet (2°52')		12.7 (1/2")	<b>037496 ●</b>
Collet (2°52')		15.88 (5/8")	<b>037502 ●</b>
Collet (2°52')		19.05 (3/4")	<b>037497 ●</b>
Collet (2°52')		25.4 (1")	<b>037508 ●</b>
Sickle spanner	58/62		<b>005458 ●</b>
Collet chuck nut with ball bearing	M48x2		<b>005714 ●</b>
Chip-Balluff	511 Bytes		<b>081309 ●</b>
Chip-Balluff	2047 Bytes		<b>081330 □</b>

Collet chuck HSK-E 63

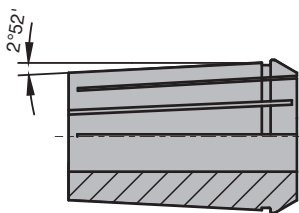

Collet angle 2°52': DIN ISO 10897

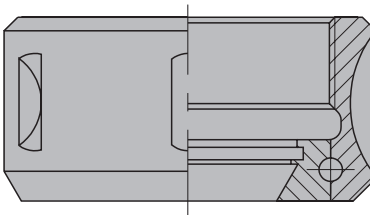

Ball bearing collet nut

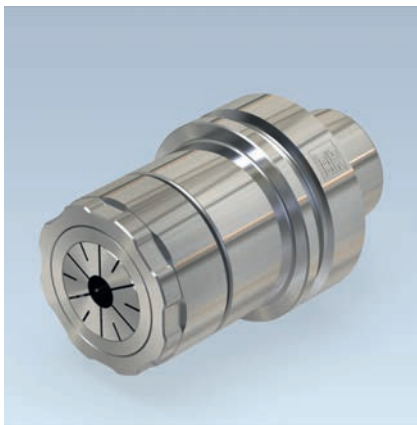

### NiRo Collet chuck *Premium* with hollow taper shank HSK-F 63

#### Application:

Precision tool chuck especially for use in difficult climatic conditions with collet for clamping shank tools with cylindrical shank and shank diameters up to  $d_{max} = 25.4$  mm (1").

#### Technical information:

Long tool life due to the use of corrosion-resistant steel. Hollow taper shank as per DIN 69893. Exact concentric running through hardened, ground and double slotted collets. Easy handling as loosening the ball bearing collet nut automatically opens the collet. Suitable for right hand and left hand rotation because of ball bearing collet nut. Ball bearing collet nut for increased clamping forces and improved concentricity compared to monobloc design. Tool chuck and collet nut fine balanced. Suitable mounting device VN 799 0 see section Knives and Spare Parts. Easy and safe clamping and releasing by clamping key with optimised spanner flats.

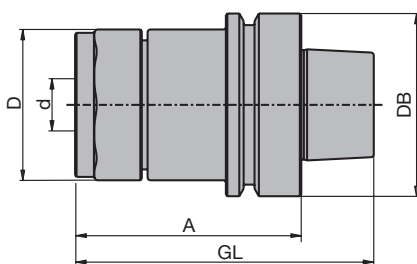

#### HSK-F 63, DIN 69893, A = 78, diameter range 6-25.4 mm

PM 350 0 17

d	D	DB	A	GL	Weight	ID
mm	mm	mm	mm	mm	kg	
6 - 25,4	52	63	78	103	1.1	<b>679043 ●</b>

Sales unit consisting of clamping chuck with ball bearing collet nut, without collet or clamping key.

NiRo collet chuck Premium HSK-F 63

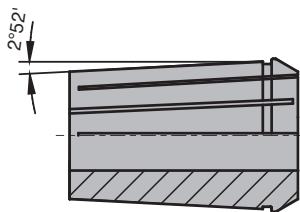

Collet angle 2°52': ISO 10897, Form B



Special key especially for NiRo collet chuck Premium

#### Spare parts:

BEZ	ABM	for S	ID
	mm	mm	
Collet (2°52')		6	<b>037429 ●</b>
Collet (2°52')		8	<b>037430 ●</b>
Collet (2°52')		10	<b>037431 ●</b>
Collet (2°52')		12	<b>037432 ●</b>
Collet (2°52')		13	<b>037433 ●</b>
Collet (2°52')		14	<b>037434 ●</b>
Collet (2°52')		16	<b>037435 ●</b>
Collet (2°52')		18	<b>037436 ●</b>
Collet (2°52')		20	<b>037437 ●</b>
Collet (2°52')		25	<b>037438 ●</b>
Collet (2°52')		6,35 (1/4")	<b>037495 ●</b>
Collet (2°52')		9,53 (3/8")	<b>037505 ●</b>
Collet (2°52')		12,7 (1/2")	<b>037496 ●</b>
Collet (2°52')		15,88 (5/8")	<b>037502 ●</b>
Collet (2°52')		19,05 (3/4")	<b>037497 ●</b>
Collet (2°52')		25,4 (1")	<b>037508 ●</b>
Clamping key			<b>117540 ●</b>
Torque wrench	9x12, 20-100 Nm		<b>117541 ●</b>
Insert for torque wrench	9x12		<b>117542 ●</b>
Collet chuck nut NiRo with ball bearing	TR44x1,5		<b>006663 ●</b>
Chip-Balluff	511 Bytes		<b>081309 ●</b>
Chip-Balluff	2047 Bytes		<b>081330 □</b>



Torque wrench with insert for precise clamping



#### Collet chuck with hollow taper shank HSK-F 63

##### Application:

Precision tool chuck with collet for clamping shank tools with cylindrical shank and shank diameters up to  $d_{max} = 30$  mm (1").

##### Technical information:

Hollow taper shank as per DIN 69893. Exact concentric running through hardened, ground and double slotted collets. Easy handling as loosening the ball bearing collet nut automatically opens the collet. Suitable for right hand and left hand rotation because of ball bearing collet nut. Ball bearing collet nut for increased clamping forces and improved concentricity compared to monobloc design. Tool chuck and collet nut fine balanced. Suitable mounting device VN 799 0 see section Knives and Spare Parts.

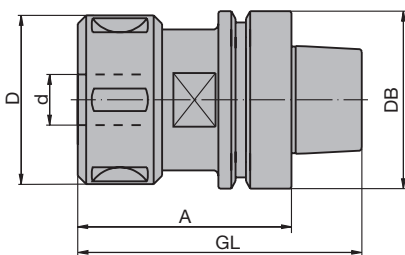

#### HSK-F 63, DIN 69893, A = 76 mm, diameter range 6-30 mm, short design, 8° taper angle of the collet

PM 350 0 15

d	D	DB	A	GL	Weight	ID
mm	mm	mm	mm	mm	kg	
6 - 30	63	63	76	101.5	1	<b>037970 ●</b>

Sales unit consisting of clamping chuck with ball bearing collet nut, without collet or spanner.

Collet chuck HSK-F 63

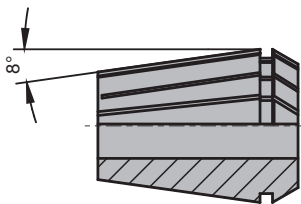

Collet angle 8°: DIN ISO 15488

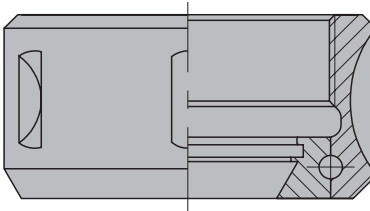

Ball bearing collet nut

##### Spare parts:

BEZ	ABM	for S	ID
	mm	mm	
Collet (8°)		6	<b>037926 ●</b>
Collet (8°)		8	<b>037927 ●</b>
Collet (8°)		10	<b>037928 ●</b>
Collet (8°)		12	<b>037929 ●</b>
Collet (8°)		14	<b>037930 ●</b>
Collet (8°)		16	<b>037931 ●</b>
Collet (8°)		20	<b>037932 ●</b>
Collet (8°)		25	<b>037933 ●</b>
Collet (8°)		30	<b>679039 ●</b>
Collet (8°)		6.35 (1/4")	<b>037934 ●</b>
Collet (8°)		9.53 (3/8")	<b>037935 ●</b>
Collet (8°)		12.7 (1/2")	<b>037936 ●</b>
Collet (8°)		15.88 (5/8")	<b>037937 ●</b>
Collet (8°)		19.05 (3/4")	<b>037938 ●</b>
Collet (8°)		25.4 (1")	<b>037939 ●</b>
Sickle spanner	58/62		<b>005458 ●</b>
Collet chuck nut with ball bearing	M50x1.5		<b>006639 ●</b>
Chip-Balluff	511 Bytes		<b>081309 ●</b>
Chip-Balluff	2047 Bytes		<b>081330 □</b>



#### Collet chuck with hollow taper shank HSK-F 63

##### Application:

Precision tool chuck with collet for clamping shank tools with cylindrical shank and shank diameters up to  $d_{max} = 25.4 \text{ mm}$  (1").

##### Technical information:

Hollow taper shank as per DIN 69893. Exact concentric running through hardened, ground and double slotted collets. Easy handling as loosening the ball bearing collet nut automatically opens the collet. Suitable for right hand and left hand rotation because of ball bearing collet nut. Ball bearing collet nut for increased clamping forces and improved concentricity compared to monobloc design. Tool chuck and collet nut fine balanced. Suitable mounting device VN 799 0 see section Knives and Spare Parts.

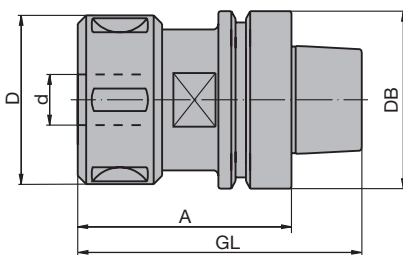

#### HSK-F 63, DIN 69893, A = 78 / 105 mm, diameter range 6-25.4 mm

PM 350 0 06

d	D	DB	A	GL	Weight	ID
mm	mm	mm	mm	mm	kg	
6 - 25.4	60	63	78	103	1.1	037412 ●
6 - 25.4	60	63	105	130	1.5	037924 ●

Sales unit consisting of clamping chuck with ball bearing collet nut, without collet or spanner.

Collet chuck HSK-F 63

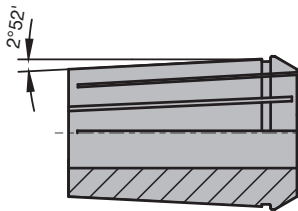

Collet angle 2°52': DIN ISO 10897

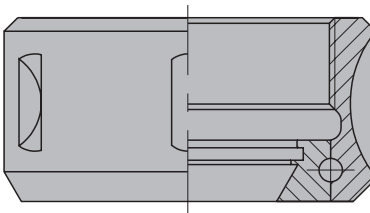

Ball bearing collet nut

##### Spare parts:

BEZ	ABM	for S	ID
	mm	mm	
Collet (2°52')		6	037429 ●
Collet (2°52')		8	037430 ●
Collet (2°52')		10	037431 ●
Collet (2°52')		12	037432 ●
Collet (2°52')		13	037433 ●
Collet (2°52')		14	037434 ●
Collet (2°52')		16	037435 ●
Collet (2°52')		18	037436 ●
Collet (2°52')		20	037437 ●
Collet (2°52')		25	037438 ●
Collet (2°52')		6.35 (1/4")	037495 ●
Collet (2°52')		9.53 (3/8")	037505 ●
Collet (2°52')		12.7 (1/2")	037496 ●
Collet (2°52')		15.88 (5/8")	037502 ●
Collet (2°52')		19.05 (3/4")	037497 ●
Collet (2°52')		25.4 (1")	037508 ●
Sickle spanner	58/62		005458 ●
Collet chuck nut with ball bearing	M48x2		005714 ●
Chip-Balluff	511 Bytes		081309 ●
Chip-Balluff	2047 Bytes		081330 □





### Collet chuck with hollow taper shank HSK-F 63, HSC machining

#### Application:

Precision tool chuck with collet for clamping shank tools with cylindrical shank. For speeds up to  $n_{max} = 30000 \text{ min}^{-1}$ .

#### Technical information:

Hollow taper shank as per DIN 69893. Exact concentric running through hardened, ground and double slotted collets. Vibration free cutting by short design. Easy handling as loosening the ball bearing collet nut automatically opens the collet. Suitable for right hand and left hand rotation because of ball bearing collet nut. Ball bearing collet nut for increased clamping forces and improved concentricity compared to monobloc design. Tool chuck and collet nut fine balanced. Suitable mounting device VN 799 0 see section Knives and Spare Parts.

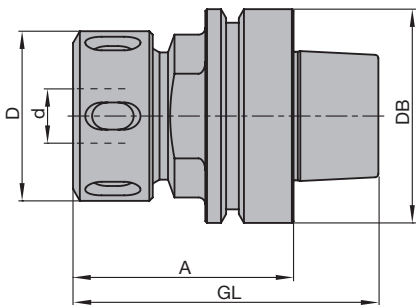

**HSK-F 63, DIN 69893, A = 65 mm diameter range up to 20 mm,**

$n_{max} = 30000 \text{ min}^{-1}$

PM 350 0 15

d	D	DB	A	GL	Weight	ID
mm	mm	mm	mm	mm	kg	
6 - 20	50	63	65	90	0.85	<b>679041 ●</b>

Sales unit consisting of clamping chuck with ball bearing collet nut, without collet or spanner.

#### Spare parts:

BEZ	ABM	for S	ID
	mm	mm	
Collet (8°)		6	<b>037439 ●</b>
Collet (8°)		8	<b>037440 ●</b>
Collet (8°)		10	<b>037441 ●</b>
Collet (8°)		12	<b>037442 ●</b>
Collet (8°)		13	<b>037443 ●</b>
Collet (8°)		14	<b>037444 ●</b>
Collet (8°)		16	<b>037445 ●</b>
Collet (8°)		18	<b>037446 ●</b>
Collet (8°)		20	<b>037447 ●</b>
Collet (8°)		6.35 (1/4")	<b>037509 ●</b>
Collet (8°)		9.53 (3/8")	<b>037510 ●</b>
Collet (8°)		12.7 (1/2")	<b>037511 ●</b>
Collet (8°)		15.88 (5/8")	<b>037507 ●</b>
Collet (8°)		19.05 (3/4")	<b>037506 ●</b>
Sickle spanner	45/50		<b>005491 ●</b>
Collet chuck nut with ball bearing	M40x1.5		<b>005718 ●</b>
Chip-Balluff	511 Bytes		<b>081309 ●</b>
Chip-Balluf	2047 Bytes		<b>081330 □</b>

Collet chuck HSK-F 63

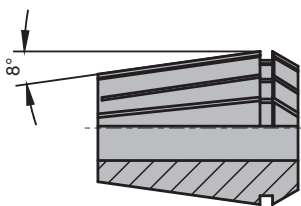

Collet angle 8°: DIN ISO 15488

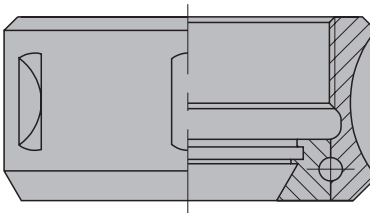

Ball bearing collet nut

#### Table for max. tool projection:

shank diameter d	max. projection
20	2,2 x d
12-16	3,0 x d
6-10	3,0 x d



### Collet chuck with hollow taper shank HSK-F 80

#### Application:

Precision tool chuck with collet for clamping shank tools with cylindrical shank and shank diameters up to  $d_{max} = 30$  mm (1").

#### Technical information:

Hollow taper shank as per DIN 69893. Exact concentric running through hardened, ground and double slotted collets. Easy handling as loosening the ball bearing collet nut automatically opens the collet. Suitable for right hand and left hand rotation because of ball bearing collet nut. Ball bearing collet nut for increased clamping forces and improved concentricity compared to monobloc design. Tool chuck and collet nut fine balanced. Suitable mounting device VN 799 0 see section Knives and Spare Parts.

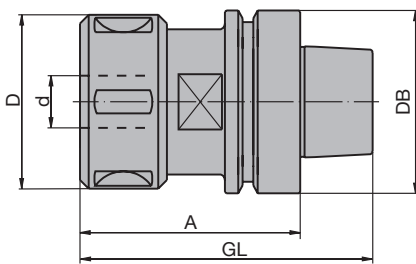

#### HSK-F 80, DIN 69893, A = 78 mm, diameter range 6-30 mm, short design, 8° taper angle of the collet

PM 350 0 15

d	D	DB	A	GL	Weight	ID
mm	mm	mm	mm	mm	kg	
6 - 30	63	80	78	110	1.6	<b>679044 ●</b>

Sales unit consisting of clamping chuck with ball bearing collet nut, without collet or spanner.

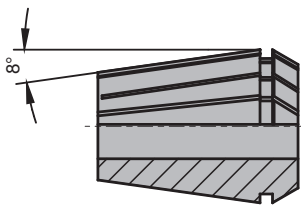

Collet angle 8°: DIN ISO 15488

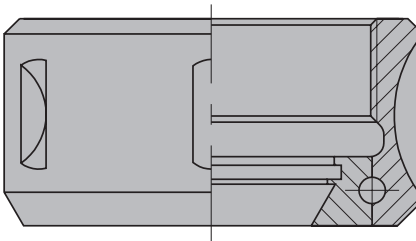

Ball bearing collet nut

#### Spare parts:

BEZ	ABM	for S	ID
	mm	mm	
Collet (8°)		6	<b>037926 ●</b>
Collet (8°)		8	<b>037927 ●</b>
Collet (8°)		10	<b>037928 ●</b>
Collet (8°)		12	<b>037929 ●</b>
Collet (8°)		14	<b>037930 ●</b>
Collet (8°)		16	<b>037931 ●</b>
Collet (8°)		20	<b>037932 ●</b>
Collet (8°)		25	<b>037933 ●</b>
Collet (8°)		30	<b>679039 ●</b>
Collet (8°)		6,35 (1/4")	<b>037934 ●</b>
Collet (8°)		9,53 (3/8")	<b>037935 ●</b>
Collet (8°)		12,7 (1/2")	<b>037936 ●</b>
Collet (8°)		15,88 (5/8")	<b>037937 ●</b>
Collet (8°)		19,05 (3/4")	<b>037938 ●</b>
Collet (8°)		25,4 (1")	<b>037939 ●</b>
Sickle spanner	58/62		<b>005458 ●</b>
Collet chuck nut with ball bearing	M50x1.5		<b>006639 ●</b>
Chip-Balluff	511 Bytes		<b>081309 ●</b>
Chip-Balluff	2047 Bytes		<b>081330 □</b>



### Collet chuck with hollow taper shank HSK 85 WS

#### Application:

Precision tool chuck with collet for clamping shank tools with cylindrical shank and shank diameters up to  $d_{max} = 30$  mm (1").

#### Technical information:

Exact concentric running through hardened, ground and double slotted collets. Easy handling by automatic collet opening when loosening the collet nut. Suitable for right hand and left hand rotation because of ball bearing collet nut. Ball bearing collet nut for increased clamping forces and improved concentricity compared to monobloc design. Tool chuck and collet nut fine balanced. Suitable mounting device ID **079010**.

**HSK 85 WS, A = 61 mm, diameter range 6-30 mm, 8° taper angle of the collet**  
PM 350 0 15

Machine	d mm	D mm	DB mm	A mm	GL mm	Weight kg	ID
Weinig	6 - 30	63	85	61	93	1.2	<b>679038</b>

Sales unit consisting of clamping chuck with ball bearing collet nut, without collet or spanner.

#### Spare parts:

BEZ	ABM mm	for S mm	ID
Collet (8°)		6	<b>037926 ●</b>
Collet (8°)		8	<b>037927 ●</b>
Collet (8°)		10	<b>037928 ●</b>
Collet (8°)		12	<b>037929 ●</b>
Collet (8°)		14	<b>037930 ●</b>
Collet (8°)		16	<b>037931 ●</b>
Collet (8°)		20	<b>037932 ●</b>
Collet (8°)		25	<b>037933 ●</b>
Collet (8°)		30	<b>679039 ●</b>
Collet (8°)		6.35 (1/4")	<b>037934 ●</b>
Collet (8°)		9.53 (3/8")	<b>037935 ●</b>
Collet (8°)		12.7 (1/2")	<b>037936 ●</b>
Collet (8°)		15.88 (5/8")	<b>037937 ●</b>
Collet (8°)		19.05 (3/4")	<b>037938 ●</b>
Collet (8°)		25.4 (1")	<b>037939 ●</b>
Sickle spanner	58/62		<b>005458 ●</b>
Collet chuck nut with ball bearing	M50x1.5		<b>006639 ●</b>

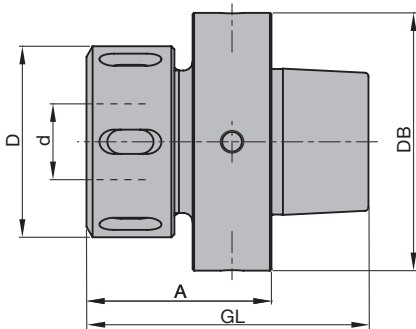

Collet chuck HSK 85 WS

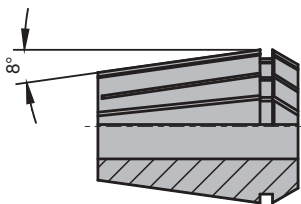

Collet angle 8°: DIN ISO 15488

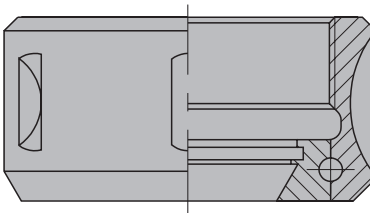

Ball bearing collet nut

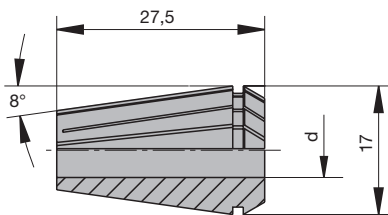

ER 16 collet diameter range  
6-10 mm

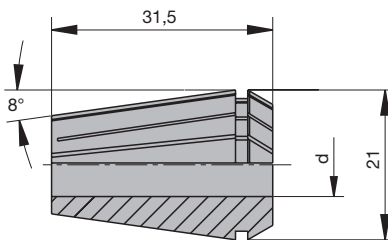

ER 20 collet diameter range  
6-13 mm

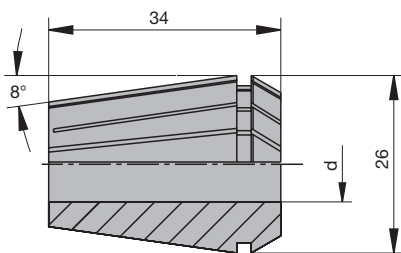

ER 25 collet diameter range  
6-16 mm

#### Collets, type ER, DIN ISO 15488

##### Application:

For collet chucks and multi spindle units and trimming units with 8° taper angle (type ER, DIN ISO 15488).

##### Technical information:

Double slotted design for maximum clamping forces and concentricity.

##### Diameter range 6-10 mm, ER 16, Type 426E, DIN ISO 15488

PM 150 0

BEZ	for S mm	d mm	D mm	GL mm	ID
Collet (8°)	6	5.5 - 6	17	27.5	037972 ●
Collet (8°)	8	7.5 - 8	17	27.5	037973 ●
Collet (8°)	10	9.5 - 10	17	27.5	037974 ●
Collet (8°)	6.35 (1/4")	5.85 - 6.35	17	27.5	679022 ●
Collet (8°)	9.53 (3/8")	9.03 - 9.53	17	27.5	679023 ●

##### Spare parts:

BEZ	ABM mm	D mm	Diameter range mm	DRI	ID
Sickle spanner	30/32		6 - 10		005516 ●
Collet chuck nut with ball bearing	M22x1.5	32	6 - 10	RH	006645 ●

##### Diameter range 6-13 mm, ER 20, Type 428E, DIN ISO 15488

PM 150 0

BEZ	for S mm	d mm	D mm	GL mm	ID
Collet (8°)	6	5.5 - 6	21	31.5	037975 ●
Collet (8°)	8	7.5 - 8	21	31.5	037976 ●
Collet (8°)	10	9.5 - 10	21	31.5	037977 ●
Collet (8°)	12	11.5 - 12	21	31.5	037978 ●
Collet (8°)	6.35 (1/4")	5.85 - 6.35	21	31.5	679024 ●
Collet (8°)	9.53 (3/8")	9.03 - 9.53	21	31.5	679025 ●
Collet (8°)	12.7 (1/2")	12.2 - 12.7	21	31.5	679026 ●

##### Spare parts:

BEZ	ABM mm	D mm	Diameter range mm	DRI	ID
Sickle spanner	34/36		6 - 12.7		005498 ●
Collet chuck nut with ball bearing	M25x1.5	35	6 - 13	RH	006647 ●

##### Diameter range 6-16 mm, ER 25, Type 430E, DIN ISO 15488

PM 150 0

BEZ	for S mm	d mm	D mm	GL mm	ID
Collet (8°)	6	5.5 - 6	26	34	037979 ●
Collet (8°)	8	7.5 - 8	26	34	037980 ●
Collet (8°)	10	9.5 - 10	26	34	037981 ●
Collet (8°)	12	11.5 - 12	26	34	037982 ●
Collet (8°)	14	13.5 - 14	26	34	037983 ●
Collet (8°)	16	15.5 - 16	26	34	037984 ●
Collet (8°)	6.35 (1/4")	5.85 - 6.35	26	34	679027 ●
Collet (8°)	9.53 (3/8")	9.03 - 9.53	26	34	679028 ●
Collet (8°)	12.7 (1/2")	12.2 - 12.7	26	34	679029 ●
Collet (8°)	15.88 (5/8")	15.38 - 15.88	26	34	679030 ●

##### Spare parts:

BEZ	ABM mm	D mm	Diameter range mm	DRI	ID
Sickle spanner	40/42		6 - 16		005518 ●
Collet chuck nut with ball bearing	M32x1.5	42	6 - 16	RH	006649 ●

## 7. Clamping systems

## 7.3 Clamping chucks

### 7.3.3 Collet chucks

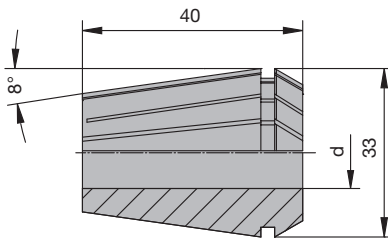

ER 32 collet diameter range  
6-20 mm

#### Diameter range 6-20 mm, ER 32, Type 470E, DIN ISO 15488

PM 150 0

BEZ	for S mm	d mm	D mm	GL mm	ID
Collet (8°)	6	5.5 - 6	33	40	037439 ●
Collet (8°)	8	7.5 - 8	33	40	037440 ●
Collet (8°)	10	9.5 - 10	33	40	037441 ●
Collet (8°)	12	11.5 - 12	33	40	037442 ●
Collet (8°)	13	12.5 - 13	33	40	037443 ●
Collet (8°)	14	13.5 - 14	33	40	037444 ●
Collet (8°)	16	15.5 - 16	33	40	037445 ●
Collet (8°)	18	17.5 - 18	33	40	037446 ●
Collet (8°)	20	19.5 - 20	33	40	037447 ●
Collet (8°)	6.35 (1/4")	5.85 - 6.35	33	40	037509 ●
Collet (8°)	9.53 (3/8")	9.03 - 9.53	33	40	037510 ●
Collet (8°)	12.7 (1/2")	12.2 - 12.7	33	40	037511 ●
Collet (8°)	15.88 (5/8")	15.38 - 15.88	33	40	037507 ●
Collet (8°)	19.05 (3/4")	18.55 - 19.05	33	40	037506 ●

#### Spare parts:

BEZ	ABM mm	D mm	Diameter range mm	DRI ID
Sickle spanner	45/50			005491 ●
Collet chuck nut with ball bearing	M40x1.5	50	6 - 20	RH 005718 ●

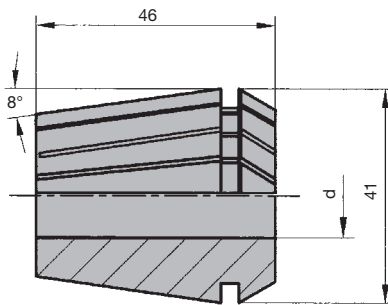

ER 40 collet diameter range  
6-26 mm

#### Diameter range 6-26 mm, ER 40, Type 472E, DIN ISO 15488

PM 150 0

BEZ	for S mm	d mm	D mm	GL mm	ID
Collet (8°)	6	5.5 - 6	41	46	037926 ●
Collet (8°)	8	7.5 - 8	41	46	037927 ●
Collet (8°)	10	9.5 - 10	41	46	037928 ●
Collet (8°)	12	11.5 - 12	41	46	037929 ●
Collet (8°)	14	13.5 - 14	41	46	037930 ●
Collet (8°)	16	15.5 - 16	41	46	037931 ●
Collet (8°)	20	19.5 - 20	41	46	037932 ●
Collet (8°)	25	24.5 - 25	41	46	037933 ●
Collet (8°)	30	29.5 - 30	41	46	679039 ●
Collet (8°)	6.35 (1/4")	5.85 - 6.35	41	46	037934 ●
Collet (8°)	9.53 (3/8")	9.03 - 9.53	41	46	037935 ●
Collet (8°)	12.7 (1/2")	12.2 - 12.7	41	46	037936 ●
Collet (8°)	15.88 (5/8")	15.38 - 15.88	41	46	037937 ●
Collet (8°)	19.05 (3/4")	18.55 - 19.05	41	46	037938 ●
Collet (8°)	25.4 (1")	24.9 - 25.4	41	46	037939 ●

#### Spare parts:

BEZ	ABM mm	D mm	Diameter range mm	DRI ID
Sickle spanner	58/62		6 - 25.4	005458 ●
Collet chuck nut with ball bearing	M50x1.5	63	6 - 25.4	RH 006639 ●



#### Collets, DIN ISO 10897, taper ratio 1:10

##### Application:

For collet chucks as well as for multi spindle units and trimming units with 2°52' taper angle (taper ratio 1:10).

##### Technical information:

Double slotted design for maximum clamping forces and concentricity.

##### Diameter range 6-12.7 mm, Type 407E, DIN ISO 10897

PM 150 0

BEZ	for S mm	d mm	D mm	GL mm	ID
Collet (2°52')	6	6	19.8	34	<b>679013 ●</b>
Collet (2°52')	7	7	19.8	34	<b>679015 ●</b>
Collet (2°52')	8	8	19.8	34	<b>679016 ●</b>
Collet (2°52')	9	9	19.8	34	<b>679017 ●</b>
Collet (2°52')	10	10	19.8	34	<b>679019 ●</b>
Collet (2°52')	12	12	19.8	34	<b>679020 ●</b>
Collet (2°52')	6.35 (1/4")	6.35	19.8	34	<b>679014 ●</b>
Collet (2°52')	9.53 (3/8")	9.53	19.8	34	<b>679018 ●</b>
Collet (2°52')	12.7 (1/2")	12.7	19.8	34	<b>679021 ●</b>

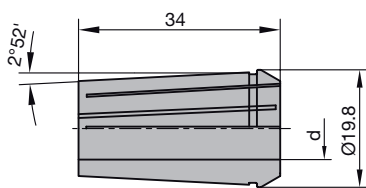

Collet type 407E diameter range 6-12.7 mm

##### Spare parts:

BEZ	ABM mm	D mm	Diameter range mm	DRI	ID
Sickle spanner	34/36		6 - 12.7		<b>005498 ●</b>
Collet chuck nut	M27x1.5	35		RH	<b>006653 ●</b>

##### Diameter range 6-16 mm, Type 415E, DIN ISO 10897

PM 150 0

BEZ	for S mm	d mm	D mm	GL mm	ID
Collet (2°52')	6	6	25.5	40	<b>679005 ●</b>
Collet (2°52')	8	8	25.5	40	<b>679032 ●</b>
Collet (2°52')	9	9	25.5	40	<b>679033 ●</b>
Collet (2°52')	9.5	9.5	25.5	40	<b>679034 ●</b>
Collet (2°52')	10	10	25.5	40	<b>679006 ●</b>
Collet (2°52')	11	11	25.5	40	<b>679035 ●</b>
Collet (2°52')	12	12	25.5	40	<b>679036 ●</b>
Collet (2°52')	13	13	25.5	40	<b>679007 ●</b>
Collet (2°52')	14	14	25.5	40	<b>679037 ●</b>
Collet (2°52')	16	16	25.5	40	<b>679008 ●</b>
Collet (2°52')	6.35 (1/4")	6.35	25.5	40	<b>679009 ●</b>
Collet (2°52')	9.53 (3/8")	9.53	25.5	40	<b>679010 ●</b>
Collet (2°52')	12.7 (1/2")	12.7	25.5	40	<b>679011 ●</b>
Collet (2°52')	15.88 (5/8")	15.88	25.5	40	<b>679012 ●</b>

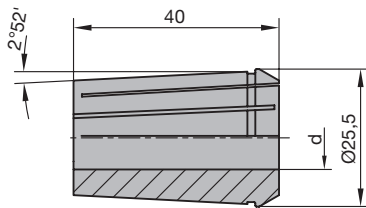

Collet type 415E diameter range 6-16 mm

##### Spare parts:

BEZ	ABM mm	D mm	Diameter range mm	DRI	ID
Sickle spanner	40/42		6 - 16		<b>005469 ●</b>
Collet chuck nut with ball bearing	M33x1.5	43		RH	<b>005685 ●</b>

## 7. Clamping systems

### 7.3 Clamping chucks

#### 7.3.3 Collet chucks

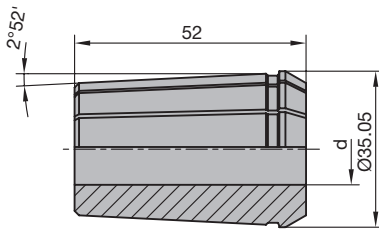

Collet type 462E diameter range  
6-25.4 mm

#### Diameter range 6-25.4 mm, Type 462E, DIN ISO 10897

PM 150 0

BEZ	for S mm	d mm	D mm	GL mm	ID
Collet (2°52')	6	6	35.05	52	<b>037429 ●</b>
Collet (2°52')	8	8	35.05	52	<b>037430 ●</b>
Collet (2°52')	10	10	35.05	52	<b>037431 ●</b>
Collet (2°52')	12	12	35.05	52	<b>037432 ●</b>
Collet (2°52')	13	13	35.05	52	<b>037433 ●</b>
Collet (2°52')	14	14	35.05	52	<b>037434 ●</b>
Collet (2°52')	16	16	35.05	52	<b>037435 ●</b>
Collet (2°52')	18	18	35.05	52	<b>037436 ●</b>
Collet (2°52')	20	20	35.05	52	<b>037437 ●</b>
Collet (2°52')	25	25	35.05	52	<b>037438 ●</b>
Collet (2°52')	6.35 (1/4")	6.35	35.05	52	<b>037495 ●</b>
Collet (2°52')	9.53 (3/8")	9.53	35.05	52	<b>037505 ●</b>
Collet (2°52')	12.7 (1/2")	12.7	35.05	52	<b>037496 ●</b>
Collet (2°52')	15.88 (5/8")	15.88	35.05	52	<b>037502 ●</b>
Collet (2°52')	19.05 (3/4")	19.05	35.05	52	<b>037497 ●</b>
Collet (2°52')	25.4 (1")	25.4	35.05	52	<b>037508 ●</b>

#### Spare parts:

BEZ	ABM mm	D mm	Diameter range mm	DRI	ID
Sickle spanner	58/62		6 - 25.4		<b>005458 ●</b>
Collet chuck nut with ball bearing	M48x2	60		RH	<b>005714 ●</b>

## 7. Clamping systems

### 7.3 Clamping chucks

#### 7.3.4 Weldon chucks

<b>Application</b>	High-stability shank tool clamping.
<b>Machine</b>	Stationary routers with CNC control and spindles for automatic tool change. Milling machines with spindles for automatic tool change.
<b>Technical features</b>	Weldon chucks are used to clamp shank tools rigidly. Weldon chucks have a similar rigidity to shrink-fit chucks, but the run out tolerance of shrink-fit chucks is significantly higher. Shrink-fit chucks are recommend for machining operations demanding high quality.

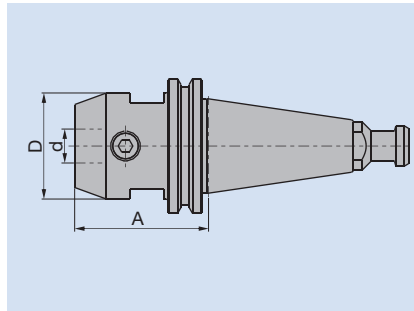

D	Largest diameter of the chuck in the clamping area
d	Clamping or bore diameter
A	Length from the reference point on the steep taper or the HSK reference surface

<b>Permissible shank tolerances</b>	Tools clamped in weldon chucks must have at least the following tool shank tolerances:
-------------------------------------	--

	Diameter of shank	
	Tools mounted in Weldon chucks	16 mm ISO g7

<b>Clamping flat</b>	The shanks of tools clamped in Weldon chucks must have a driving flat to DIN 1835.
----------------------	--

The following drawing details the dimensions of the clamping flat:

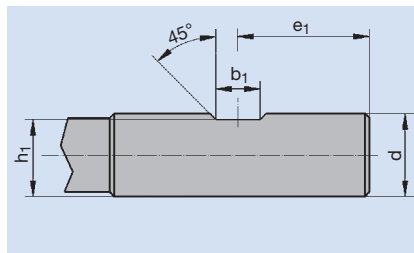

d	e <sub>1</sub>	b <sub>1</sub>	h <sub>1</sub>
16	24	10	14.2
20	25	11	18.2

<b>Application data</b>	<b>Maximum RPM</b> Maximum RPM for Weldon chucks: $n_{\max} = 24000 \text{ min}^{-1}$ .
-------------------------	--

<b>Order information</b>	Weldon chucks with adaptors SK 30 / SK 40 as well as HSK-E / HSK-F supplied on request.
--------------------------	---





#### Clamping chuck with steep taper for CNC aggregates

**Application:**

Precision tool chuck for clamping shank tools with cylindrical shank and shank diameters up to  $d_{\max} = 16$  mm.

**Technical information:**

Steep taper design for Flex 5+ aggregates (Homag Group) and 5-motion-Plus aggregate (Felder Format-4). High stability for medium difficult cutting operations. Easy tool change through opening of the radial clamping screw. Tool adaptor fine balanced. Maximum tool protrusion (length projecting of the chuck) 60 mm.

**A = 20 mm, clamping diameter 16 mm**

PM 320 0 53

Machine	d mm	D mm	DB mm	A mm	GL mm	Weight kg	ID
Felder Format-4, Homag Group	16	40	40	20	55	0.3	<b>037722</b> □

**Spare parts:**

BEZ	ABM mm	ID
Clamping screw	M8x10	<b>007800</b> □
Allen key	SW 4	<b>005434</b> ●

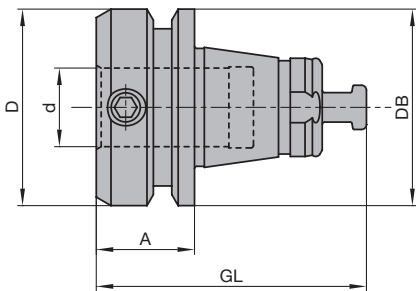

Weldon clamping chuck

Required shank design:

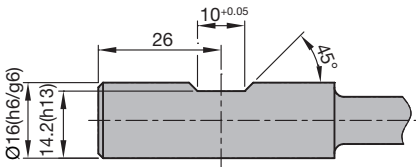

<b>Application</b>	Clamping drills.
<b>Machine</b>	Stationary routers with CNC control and spindles for automatic tool change. Milling machines with spindles for automatic tool change. Routers without automatic tool change. Drilling machines.
<b>Technical features</b>	1. Conventional drill adaptors Drill adaptors are used to mount dowel drills, through hole drills or hinge boring bits in drilling machines. Below an overview of the available adaptors:

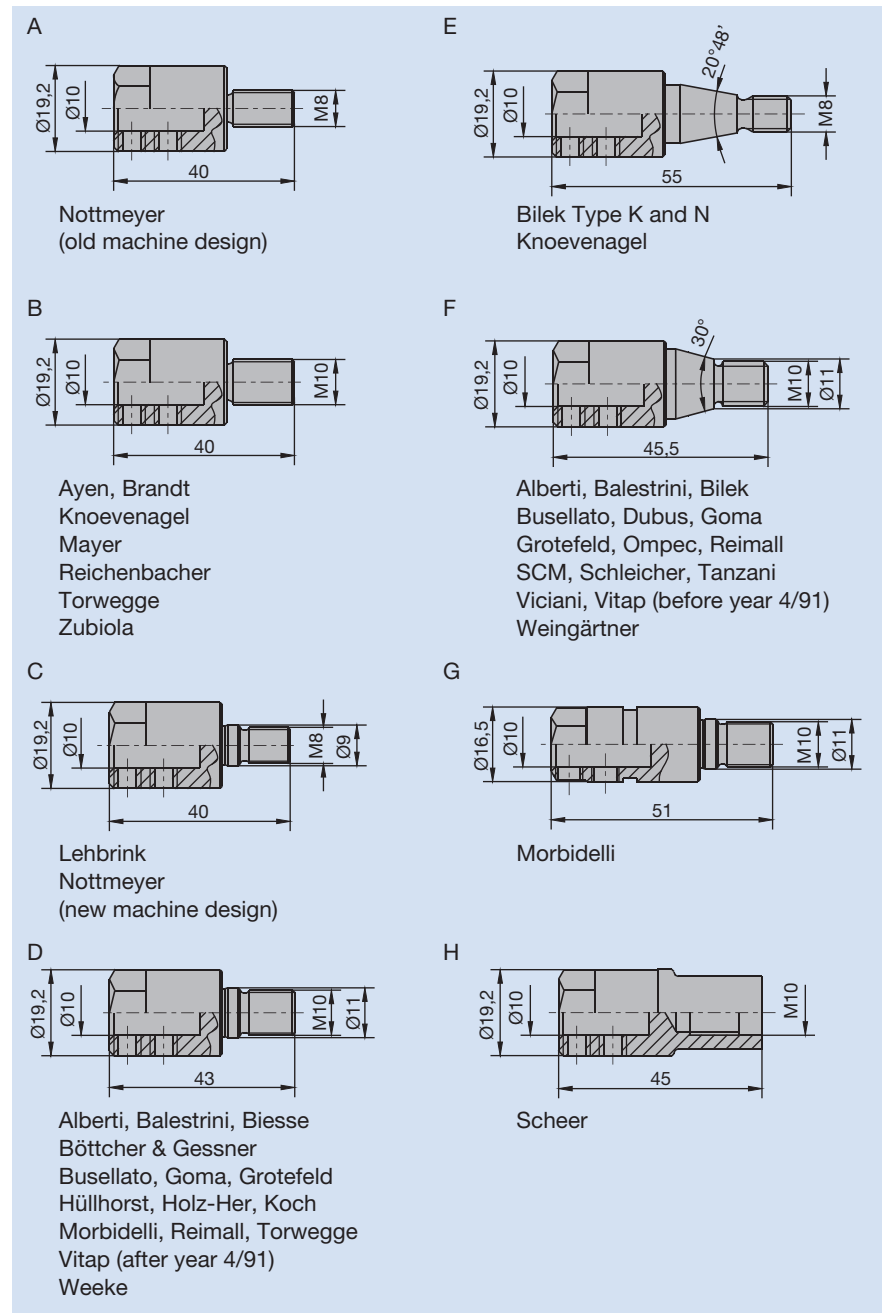

The drill is clamped in the adaptor by a screw. The shank has to have a driving flat.

##### 2. Drill chuck for CNC machining centres

Drill chucks are an easy way to carry drills in machines with magazines. The drill chuck is a 3 wedge chuck with an interface to suit the tool spindle.

D	Largest external diameter of the chuck
d	Clamping diameter
A	Length from the reference point (steep taper) or reference surface (HSK)

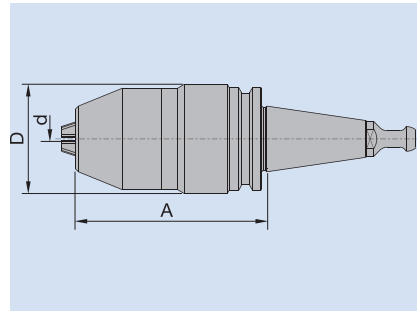

##### 3. Quick change adaptor

Adaptor system for dowel drills, through hole drills and hinge boring bits for different drilling machines. The quick change adaptor is a quick and easy way to change drills in the machine without using tools.

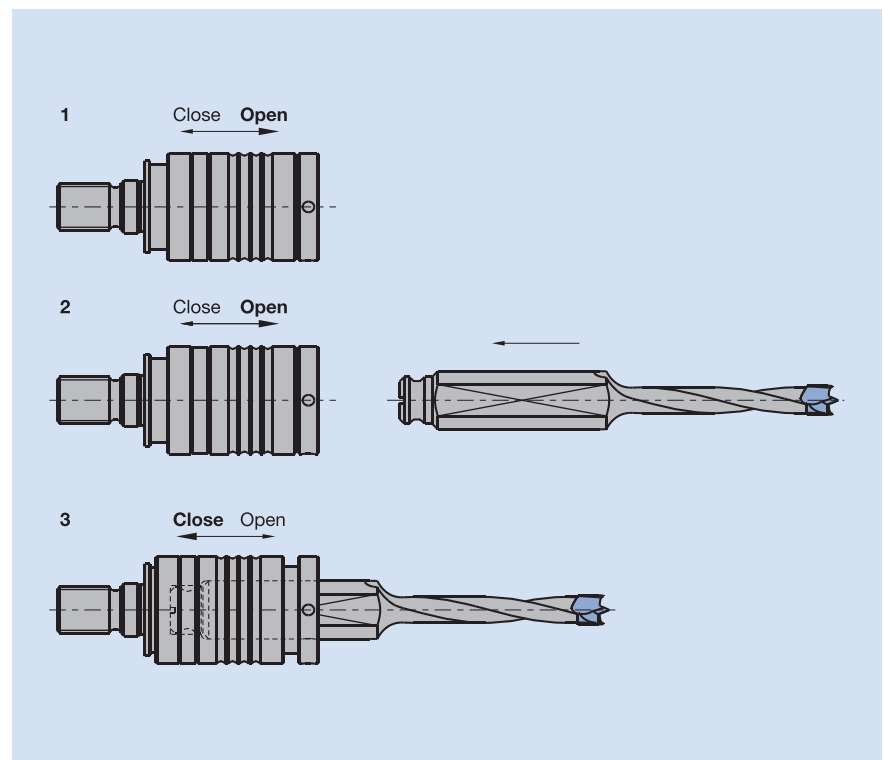

Changing a drill.

For a perfect fit of the shank a special length adjustment screw (ID **009157**) is required. This screw allows exact length adjustment of the mounted drills.

## 7. Clamping systems

### 7.3 Clamping chucks

#### 7.3.5 Drill adaptors

##### Required shank tolerance

Clamping drills safely requires the following shank and driving flat tolerance:

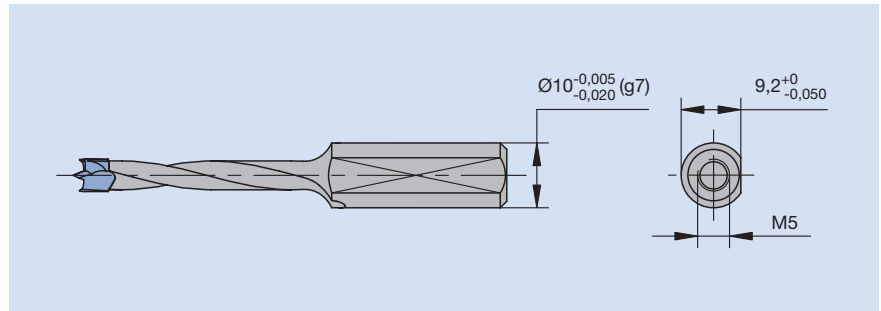

##### Application Data

##### Maximum allowable RPM

Maximum allowable RPM for drill adaptors (adaptor in spindle):

$$n_{\max} = 9000 \text{ min}^{-1}.$$

Conventional drill adaptors and quick change adaptors can be used up to

$$n_{\max} = 12000 \text{ min}^{-1}.$$



#### Drill adaptor, conventional clamping

##### Application:

Clamping chuck for drill bits with 10 mm shank diameter and driving flat for drilling spindles with threaded adaptor.

##### Technical information:

Stable and secure clamping of drills by 2 clamping screws. Smallest spindle pitch in the drilling unit: 21 mm. For narrower pitches, 8 mm shank chucks and drills must be used.

##### Clamping chuck for drills with 10 mm shank and driving flat

PM 320 0 28, PM 320 0 29, PM 320 0 30, PM 320 0 32, PM 320 0 34, PM 320 0 40, PM 320 0 42, PM 320 0 46, PM 320 0 50

Machine	GL mm	Pic.	ID LH	ID RH
Nottmeyer (old machine type)	40	A	<b>033088</b> ●	<b>033089</b> ●
Ayen, Brandt, Holzma, Homag, Knoevenagel, Mayer, Reichenbacher, Torwegge, Zubiola	40	B	<b>033092</b> ●	<b>033093</b> ●
Lehbrink, Nottmeyer (new machine type)	40	C	<b>033080</b> ●	<b>033081</b> ●
Lehbrink, Nottmeyer (new machine type)	52	C	<b>033082</b> ●	<b>033083</b> ●
Alberti, Balestrini, Biesse, Böttcher & Gessner, Busellato, Goma, Grotefeld, Holz-Her, Homag, Hüllhorst, Koch, Morbidelli, Reimall, Torwegge, Vitap (from YOM 4/91 on), Weeke	43	D	<b>033086</b> ●	<b>033087</b> ●
Bilek, Knoevenagel	55	E	<b>033084</b> ●	<b>033085</b> ●
Alberti, Balestrini, Bilek, Busellato, Dubus, Goma, Grotefeld, Ompec, Reimall, Schleicher, SCM, Tanzani, Viciani, Vitap (up to YOM 4/91), Weingärtner	45.5	F	<b>033090</b> ●	<b>033091</b> ●
Morbidelli	51	G	<b>033094</b> ●	<b>033095</b> ●
Scheer	45	H	<b>033096</b> ●	<b>033097</b> ●

##### Spare parts:

BEZ	ABM mm	ID
Allen key	SW 3	<b>005433</b> ●
Allen screw	M6x5	<b>005836</b> ●

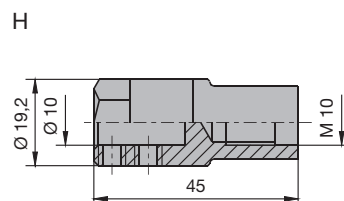
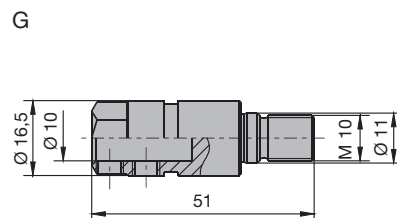
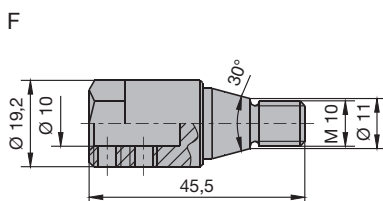
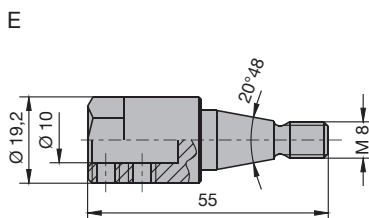
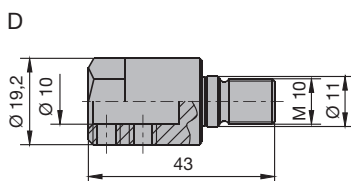
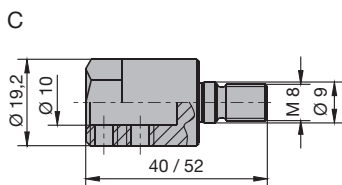
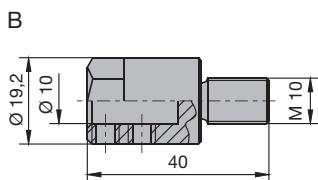
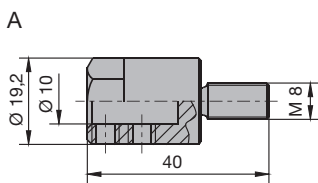

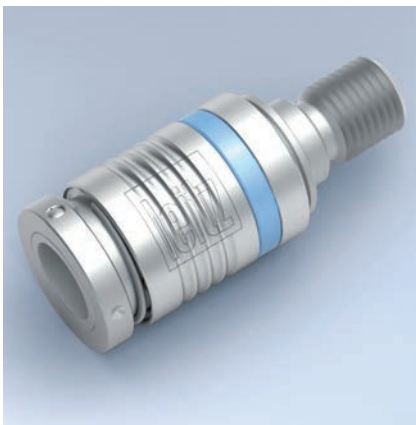

#### Drill adaptor, quick clamping design

##### Application:

Quick clamping chuck for drills with 10 mm shank and driving flat for drilling spindles with threaded adaptor.

##### Technical information:

The drill is held in the chuck by the length adjusting screw (ID **009157**). Ideal if the hole diameter must be changed quickly. Quick clamping chucks not in use should be covered using the optional dust cover.

**Note:** The drill shanks require an appropriate shank and driving flat dimensional tolerance to ensure trouble free operation. Drills from the Leitz range guarantees functional reliability. Speed up to 12000 min<sup>-1</sup> (quick change drill adaptor without drill must be covered with the dust cover ID **115521** for speeds exceeding 9000 min<sup>-1</sup> to prevent unbalance).

##### Clamping chuck for drills with 10 mm shank and driving flat

PM 320 0, PM 320 0 55, PM 320 0 56, PM 320 0 57, PM 320 0 58, PM 320 0 59

Machine	BEM	GL mm	Pic. A	ID LH	ID RH
Lehbrink, Nottmeyer (new machine type)		45	A	<b>033102</b>	<b>033103</b>
Ayen, Brandt, Holzma, Homag, Knoevenagel, Mayer, Reichen- bacher, Torwegge, Zubiola		45	B	<b>033104</b>	<b>033105</b>
Nottmeyer (old machine type)		45	C	<b>033098</b>	<b>033099</b>
Alberti, Biesse, Böttcher & Gessner, Busellato, Goma, Grotefeld, Holz-Her, Homag, Hüllhorst, Koch, Morbidelli, Reimall, Torwegge, Vitap (from YOM 4/91 on), Weeke		46	D	<b>033100</b>	<b>033101</b>
Homag, Weeke	from year of con- struction 2/04 on	40.25	E	<b>033109</b>	<b>033110</b>
Universal	Shank D-10 mm	50	F	<b>033106</b>	<b>033106</b>

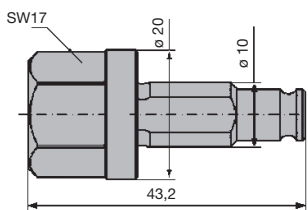

Mounting device ID **115522**

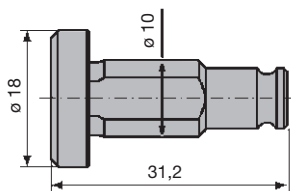

Dust cover ID **115521**

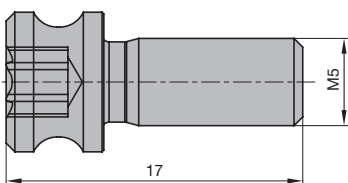

Length adjustment screw ID **009157**

##### Spare parts:

BEZ	ABM mm	ID
Dust cover	d8/10/D18/L31.2	<b>115521</b>
Mounting device	d8/10/D20/L43.2/SW17	<b>115522</b>
Length adjustment screw	M5x17	<b>009157</b>
	Torx® 20	

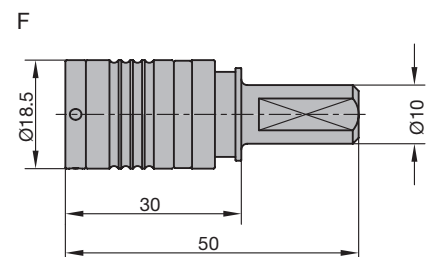
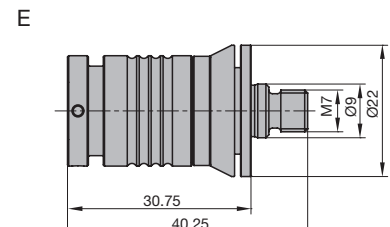
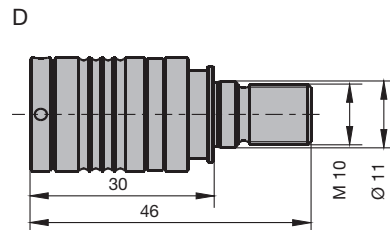
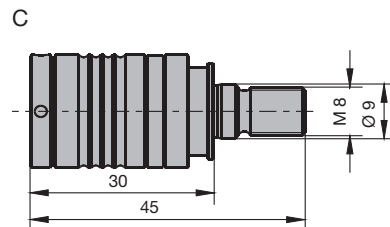
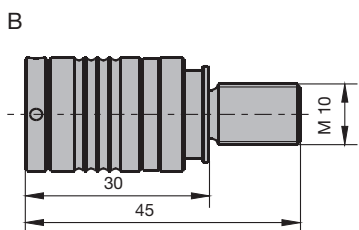
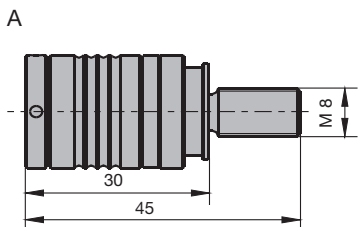



#### Drill adaptor

##### Application:

For mounting dowel drills, through hole drills and hinge boring bits on point-to-point drilling machines, through feed drilling machines and stationary drilling machines.

##### Technical information:

Wear resistant material, ground surface. High concentricity for clean holes and long drill life time.

##### For Weeke through-feed machines

PM 320 0

Machine	d mm	D mm	GL mm	ID
Homag, Weeke	10	20	46	<b>033107 ●</b>

##### Spare parts:

BEZ	ABM mm	ID
Allen key	SW 3	<b>005433 ●</b>
Allen screw	M6x4	<b>005837 ●</b>

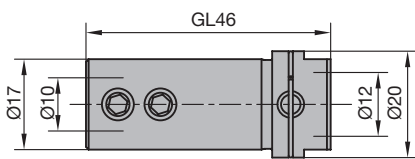

Drill adaptor for Weeke



#### Drill adaptor

##### Application:

For mounting dowel drills, through hole drills and hinge boring bits on point-to-point drilling machines, through feed drilling machines and stationary drilling machines.

##### Technical information:

Wear resistant material, ground surface. High concentricity for clean holes and long drill life time.

##### For Biesse boring units

PM 320 0

Machine	d mm	D mm	GL mm	ID
Biesse	10	20	37	<b>033108 ●</b>

##### Spare parts:

BEZ	ABM mm	ID
Allen key	SW 3	<b>005433 ●</b>
Allen screw	M6x5	<b>005836 ●</b>

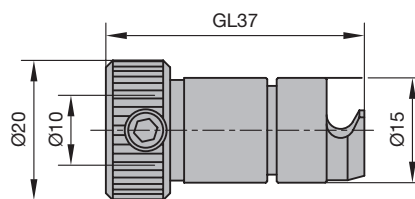

Drill adaptor for Biesse



**Quick change drill adaptor, spare parts for previous system**

**Tool adaptor for drills with 10 mm shanks**  
PM 320 0 02

d	D	GL	ID	ID
mm	mm	mm	LH	RH
10	20	29	<b>033270</b> ●	<b>033271</b> ●

**Spare parts:**

BEZ	ABM	ID
	mm	
Allen key	SW 3	<b>005433</b> ●
Allen screw	M6x5	<b>005836</b> ●

**Tool adaptor for drills with 8 mm shanks**  
PM 320 0 01

d	D	GL	ID	ID
mm	mm	mm	LH	RH
8	15.5	29	<b>033170</b> ●	<b>033171</b> ●

**Spare parts:**

BEZ	ABM	ID
	mm	
Allen key	SW 3	<b>005433</b> ●
Allen screw	M6x5	<b>005836</b> ●





### Drill chuck for CNC spindle

#### Application:

Clamping chuck for drills for CNC routers and machining centres.

#### Technical information:

Precision design with high concentricity < 0.02 mm. Special clamping mechanism with improved holding forces to prevent the tool shank from slipping. Stepless adjustable clamping range: 1-13 mm (SK 30, ISO 30, SK 40), 1-16 mm (HSK-E/-F 63). Fine balanced design. Clamping wedges hardened for improved wear resistance. Suitable for right hand and left hand rotation. Only to be used for drills.

#### Stepless adjustable clamping range

PM 330 0

Type	d mm	D mm	DB mm	A mm	GL mm	Weight kg	S mm	ID
A	1 - 13	50	50	103	174.8	1.30	SK 30	037758 □
B	1 - 13	50	50	103	174.8	1.30	SK 30	037759 □
E	1 - 13	50	63.55	87.5		1.50	SK 40	037761 ●
	1 - 16	50	63	98	129.6	1.80	HSK-E 63	037763 ●
	1 - 16	50	63	98	123	1.70	HSK-F 63	037762 ●

#### Conditions to be observed during clamping:

- Minimum clamping length  
 $l_{\min} = 20 \text{ mm}$
- Maximum clamping length  
 $l_{\max} = 29 \text{ mm}$

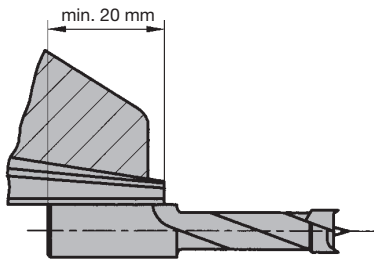

- Do not clamp tapered shanks
- If possible use cylindrical shanks
- without clamping flat, grooves or other recesses

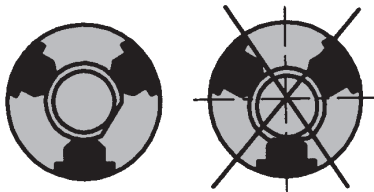

- If drills with driving flat are used, the clamping flat is not allowed to touch the clamping wedges. See illustration

#### Spare parts:

BEZ	for S mm	ABM mm	L mm	ID
Allen key	SK	SW 6	100	005447 ●
Allen key	HSK	SW 4	100	005503 ●

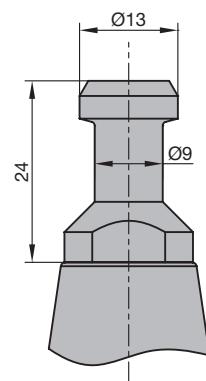

Type: A  
SK 30 pull stud as per DIN ISO 7388

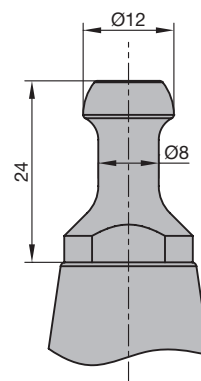

Type: B  
SK 30/ISO 30 pull stud for HSD spindles from construction year 9/92 on

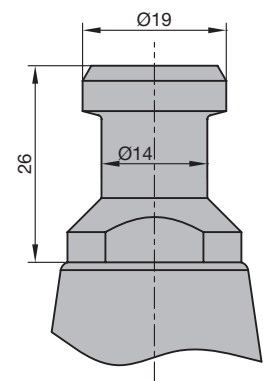

Type: E  
SK 40 pull stud as per DIN ISO 7388



## 7. Clamping systems

### 7.4 Clamping arbors 7.4.1 Hydro clamping arbors



#### Hydro clamping arbor HSK-F 63 / HSK-E 63

**Application:**

For precise and play-free mounting of tools with bore, such as sawblades, tools, toolsets and cutterheads.

**Machine:**

Machines with HSK-F 63 or HSK-E 63 adaptor, e.g. moulders, window producing machines, CNC-machining centres etc.

**Technical information:**

Hollow taper shank design as per DIN 69863. Play-free and precise adaption of bore tools through hydro clamping arbors. Axial clamping actuation of the closed hydro system. Safety against twisting of the tools through pins and screws.

**Note:** Please observe the admitted maximum weight and diameters as well as the maximum tool RPM of the machine producer!

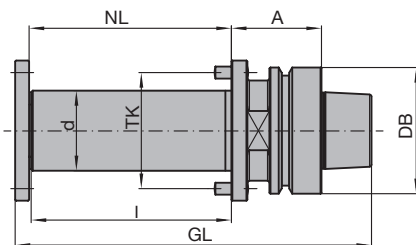

Hydro clamping arbor HSK-F 63

**HSK-F / E 63, A = 45 / 90 mm**

PH 160 0 04, PH 160 0 05

d	l	NL	A	GL	DB	TK	Weight	S	ID
mm	mm	mm	mm	mm	mm	mm	kg	mm	
40	100	101	45	178	63	58	2.18	HSK-F 63	<b>663811</b>
40	140	141	45	218	63	58	2.67	HSK-F 63	<b>663812</b>
40	190	191	45	268	63	58	3.05	HSK-F 63	<b>663813 ●</b>
40	190	191	90	313	63	58	4.41	HSK-F 63	<b>663814</b>
40	190	191	45	275	63	58	3.2	HSK-E 63	<b>663815</b>
40	190	191	90	320	63	58	4.5	HSK-E 63	<b>663816</b>

#### Hydro clamping arbor HSK-F 63 mod.

**Application:**

Hydro clamping arbor for precise and play-free mounting of tools with bore such as circular sawblades, tools, toolsets and cutterheads for high concentricity.

**Machine:**

Machines with HSK-F 63 interface, e.g. laminate and parquet flooring lines, edgbanding machines, double-end tenoners, profile cutting machines etc.

**Technical information:**

Closed hydro clamping system with maintenance free pressurising piston mechanism. User friendly axial positioned hydro clamping screw. Play-free and precise mounting of tools with bores on hydro clamping arbors. Suitable for RH and LH.

RPM  $n_{max}$  12000<sup>-1</sup>.

**Note:** Check the allowed maximum RPM of the tool mounted on the arbor!

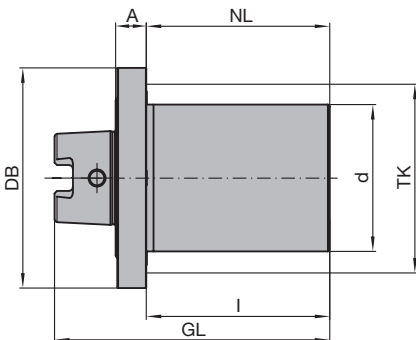

Hydro clamping arbor HSK-F 63 mod.  
PH 160 0 02

**HSK-F 63 mod. for tools with bore 60 mm, A = 12.5 mm**

PH 160 0 02

Machine	d	l	NL	GL	DB	TK	Weight	ID
	mm	mm	mm	mm	mm	mm	kg	
Homag	60	75	75	112.5	63	75	2.25	<b>663804</b>

Suitable spacers, see section Knives and Spare Parts.



### Hydro clamping arbor HSK-F 63 mod. with stepless fine adjustment

#### Application:

Hydro clamping arbor for precise and play-free mounting of tools with bore such as circular sawblades, toolsets and sets of cutterheads for high concentricity. Fine thread design of the hydro clamping arbor allows stepless fine adjustment of multi part tooling sets.

#### Machine:

Machines with HSK-F 63 adaptor, e.g. laminate and parquet flooring lines, edgebanding machines, double-end tenoners, profile cutting machines etc.

#### Technical information:

Closed hydro clamping system with maintenance free pressurising piston mechanism. User friendly axial positioned hydro clamping screw. Play-free and precise mounting of tools with bores on hydro clamping arbors. Suitable for RH and LH.

RPM  $n_{max}$  12000<sup>-1</sup>.

**Note:** Check the allowed maximum RPM of the tool mounted on the arbor!

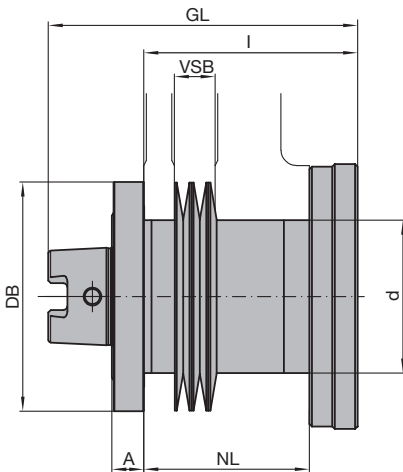

#### HSK-F 63 mod. for tools with bore 60 mm, A = 12.5 mm

PH 160 0 03

Machine	d mm	l mm	NL mm	VSB	GL mm	DB mm	TK mm	Weight kg	ID
Homag	60	75	42 - 52	10	116.5	63	75	2.8	<b>663803 ●</b>

Hydro clamping arbor HSK-F 63 mod.  
with stepless fine adjustment  
PH 160 0 03

## 7. Clamping systems

### 7.4 Clamping arbors 7.4.1 Hydro clamping arbors



#### Hydro clamping arbor HSK 85 WS

**Application:**

For precise, play-free mounting of tools with bore, such as sawblades, cutting tools, sets of cutting tools and cutterheads.

**Machine:**

Machines with HSK 85 WS adaptor e.g. moulders (Weinig Powermat), window production machines etc.

**Technical information:**

Play-free and precise mounting of tools with bore by hydro arbors. Radial clamping by closed hydro system. Easy and safe handling with optionally lifting rings.

**Note:** Observe the information of the machine producer for the permitted maximum weight and diameter as well as the maximum tool RPM!



**HSK 85 WS, A = 26 mm**

PH 160 0 01

Machine	d	l	NL	GL	DB	TK	Weight	ID
	mm	mm	mm	mm	mm	mm	kg	
Weinig	40	105.5	100	171.5	85	58	2.9	<b>663800 ●</b>
Weinig	40	175.5	170	265.5	85	58	3.8	<b>663802 ●</b>

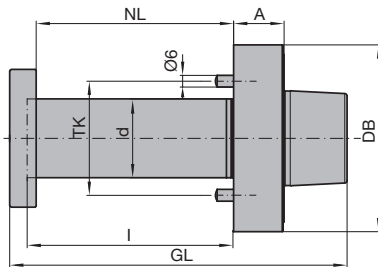

Hydro clamping arbor HSK 85 WS - PH 160 0 01

Suitable spacers, see section Knives and Spare Parts.

## 7. Clamping systems

### 7.4 Clamping arbors

#### 7.4.2 Cutter arbors

##### Application

For mounting single cutters or cuttersets with bore.

##### Machine

Stationary routers with CNC control and spindles for automatic tool change, Through-feed machines and milling machines with spindles for automatic tool change.

##### Technical features

Cutter arbors are used to mount tools, cutterheads, cutters and sawblades on CNC machining centres or trough-feed machines with spindles for automatic tool change. The arbor clamping length can be altered to suit the application and tool.

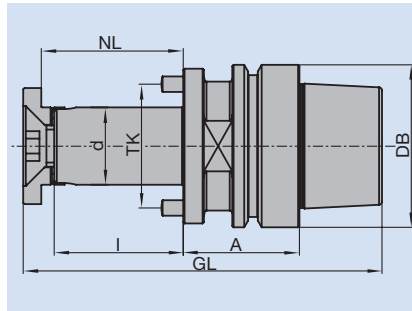

d	Diameter of the arbor
I	Clamping length
DB	Outer diameter groove
A	Length from reference point (steep taper) or reference surface (HSK)
DTK	Pitch diameter, screw or pin bore

##### Permissible bore tolerances

Tools mounted on arbors must have at least the following bore tolerance:

	Bore tolerance
Tools mounted on arbors	ISO H7

##### Information

Please observe the data of the machine producer for the allowed maximal weight and diameter as well as the maximal tool RPM!



#### Cutter arbor with cylindrical shank

##### Application:

Arbor for single tools with bore or tool sets with bore.

##### Technical information:

Cylindrical shank design. Short design for grooving cutter and sawblades up to widths NB = 10 mm. Long design for one part or multi part tools/tool sets. Safety device against tool twisting by screw or pin. Cutter arbors are fine balanced. If conical spring washers with safety device against twisting are used, slots are required in the cutter arbor.

**Note:** Maximum admissible speed  $n_{max}$  depends on the mounted tools. Please comply with the specifications regarding the maximum admissible weight and diameters detailed by the machine manufacturer.

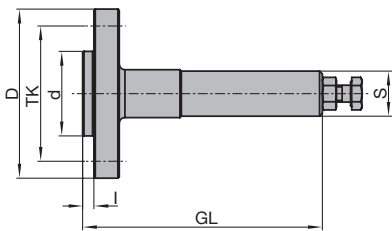

Arbor, short design

##### Short version

TI 501 0 04

d	l	D	GL	TK	S	ID
mm	mm	mm	mm	mm	mm	
30	4	60	85	48	16x50	041429 ●
30	4	59	102	48	20x50	041368 ●
30	4	59	102	48	25x60	041367 ●
30	4	59	127	48	25x60	042980 ●

With four countersunk screws M6X16. Maximum diameter for circular saw blades = 250 mm.

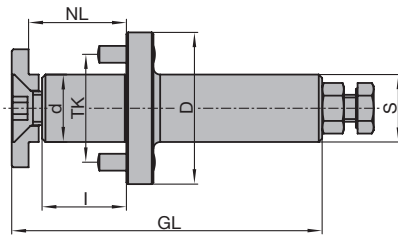

Arbor, long design

##### Long design

TI 501 0 03

d	l	NL	D	GL	TK	S	ID
mm	mm	mm	mm	mm	mm	mm	
20	25	29	50	92	32	20x50	042982 □
20	40	44	50	107	32	20x50	042983 □
20	55	59	50	122	32	20x50	042984 ●
20	40	44	50	116	32	25x60	041124 ●
20	55	59	50	131	32	25x60	041125 ●
20	70	74	50	146	32	25x60	041126 ●
30	25	30	59	95	48	20x50	042985 □
30	40	45	59	110	48	20x50	042986 ●
30	25	30	59	105	48	25x60	041127 □
30	40	45	59	120	48	25x60	041128 ●

Sales unit consisting of arbor, clamping screw and conical spring washer (flat design), without spacers.

##### Spare parts:

BEZ	ABM	for d	ID
	mm	mm	
Washer with safety device against twisting, M10	20/35x13x10.5	20	006768 ●
Washer with safety device against twisting, M16	30/45x15x16.5	30	006769 ●

Suitable spacers, see section Knives and Spare Parts.

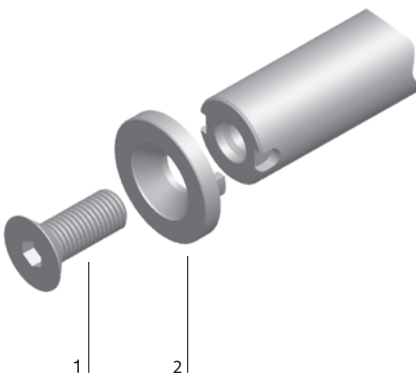

- 1 Clamping screw
- 2 Conical spring washer for safety against twisting



#### Cutter arbor with steep taper SK 30 / SK 40

**Application:**

Arbor for single tools with bore or tool sets with bore.

**Technical information:**

Steep taper design as per DIN ISO 7388, without grooves and notches. Short design, suitable for low vibration cutting. Safety device against tool twisting by screw or pin. Arbors are fine balanced. If conical spring washers with safety device against twisting are used, slots are required in the arbor. For suitable mounting device VN 799 0, see section Knives and Spare Parts.

**Note:** Please comply with the specifications regarding the maximum admissible weight and diameters detailed by the machine manufacturer!

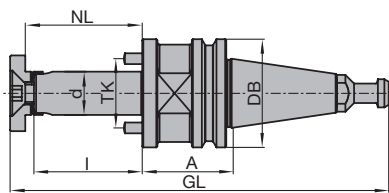

Arbor SK 30/SK 40

**SK 30, A = 42 mm**

TI 501 0 01

Type	d mm	l mm	NL mm	GL mm	DB mm	TK mm	Weight kg	ID
A	20	70	74	194.8	50	32	1	<b>041137</b> □
A	30	80	85	205.8	50	48	1.3	<b>042814</b> □
B	20	70	74	194.8	50	32	1	<b>041370</b> □
B	30	80	85	205.8	50	48	1.3	<b>041373</b> □
C	20	70	74	194.8	50	32	1	<b>042832</b> □
C	30	80	85	205.8	50	48	1.3	<b>042836</b> □

**SK 40, A = 42 mm**

TI 501 0 01

Type	d mm	l mm	NL mm	GL mm	DB mm	TK mm	Weight kg	ID
E	30	80	85	228.5	63.55	48	1.8	<b>042815</b> □

Sales unit consists of arbor with pull stud, clamping screw and conical spring washer (flat design), without spacers.

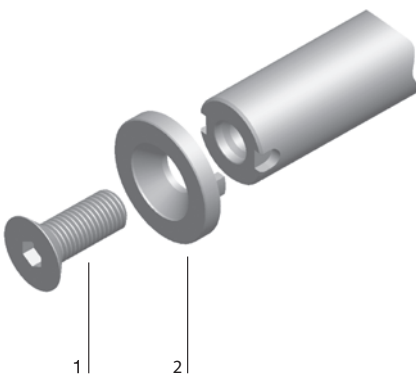

1 Clamping screw  
2 Conical spring washer for safety against twisting

**Spare parts:**

BEZ	ABM mm	for d mm	ID
Washer with safety device against twisting, M10	20/35x13x10.5	20	<b>006768</b> ●
Washer with safety device against twisting, M16	30/45x15x16.5	30	<b>006769</b> ●
Locking nut with Balluff chip	SK 40, 511 Bytes		<b>081601</b> ●

Suitable spacers, see section Knives and Spare Parts.

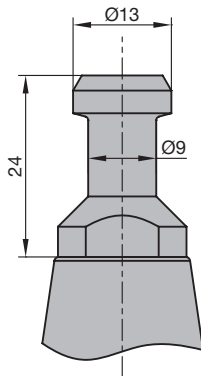

Type: A  
SK 30 pull stud as per DIN ISO 7388

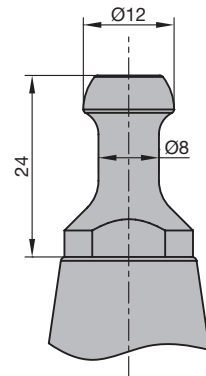

Type: B  
SK 30/ISO 30 pull stud for HSD spindles from construction year 9/92 on

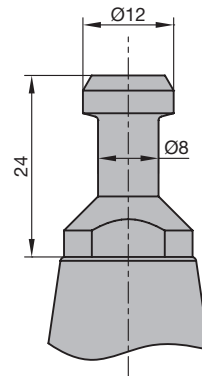

Type: C  
SK 30/ISO 30 pull stud Biesse until construction year 9/92

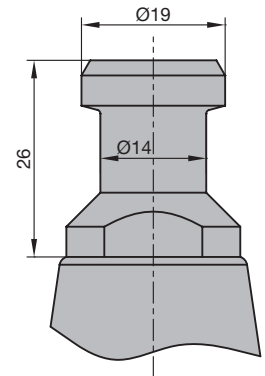

Type: E  
SK 40 pull stud as per DIN ISO 7388





#### Cutter arbor with steep taper SK 30 / SK 40

##### Application:

Arbor for single tools with bore or tool sets with bore.

##### Technical information:

Steep taper design as per DIN ISO 7388, without grooves and notches. Outside dimension A = 63 mm for longer tool length in the machine. Safety device against tool twisting by screw or pin. Arbors are fine balanced. If conical spring washers with safety device against twisting are used, slots are required in the arbor. For suitable mounting device VN 799 0, see section Knives and Spare Parts.

**Note:** Please comply with the specifications regarding the maximum admissible weight and diameters detailed by the machine manufacturer!

##### SK 30, A = 63 mm

TI 501 0 01

Type	d	l	NL	GL	DB	TK	Weight	ID
	mm	mm	mm	mm	mm	mm	kg	
A	20	70	74	215.8	50	32	1.3	<b>042818</b> □
A	30	80	85	226.8	50	48	1.6	<b>042822</b> □

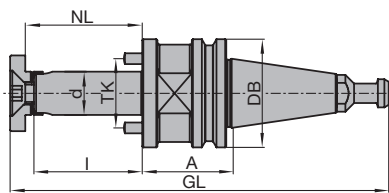

Arbor SK 30/SK 40

##### SK 40, A = 63 mm

TI 501 0 01

Type	d	l	NL	GL	DB	TK	Weight	ID
	mm	mm	mm	mm	mm	mm	kg	
E	30	80	85	249.5	63.55	48	2.2	<b>042829</b> □

Sales unit consists of arbor with pull stud, clamping screw and conical spring washer (flat design), without spacers.

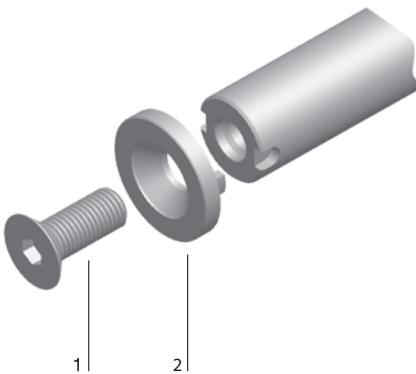

- 1 Clamping screw
- 2 Conical spring washer for safety against twisting

##### Spare parts:

BEZ	ABM	for d	ID
	mm	mm	
Washer with safety device against twisting, M10	20/35x13x10.5	20	<b>006768</b> ●
Washer with safety device against twisting, M16	30/45x15x16.5	30	<b>006769</b> ●
Locking nut with Balluff chip	SK 40, 511 Bytes		<b>081601</b> ●

Suitable spacers, see section Knives and Spare Parts.

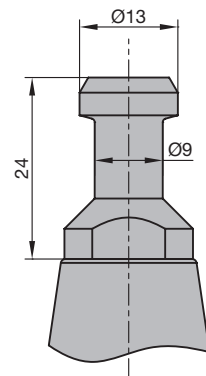

Type: A  
SK 30 pull stud as per DIN ISO 7388

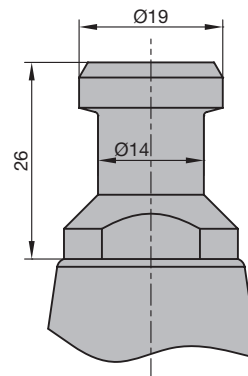

Type: E  
SK 40 pull stud as per DIN ISO 7388



### Cutting arbor with hollow taper shank HSK-E 63

**Application:**

Arbor for single tools with bore or tool sets with bore.

**Technical information:**

Hollow taper shank design as per DIN 69893. Safety device against tool twisting by screw or pin. Arbors are fine balanced. Spring washers with safety against twisting. For suitable mounting device VN 799 0, see section Knives and Spare Parts.

**Note:** Please comply with the specifications regarding the maximum admissible weight and diameters detailed by the machine manufacturer.

**HSK-E 63, DIN 69893, A = 45 mm**

TI 501 0 07

d	l	NL	GL	DB	TK	Weight	ID
mm	mm	mm	mm	mm	mm	kg	
20	70	75	159	63	32	1.2	<b>039801</b> ●
30	80	85	169	63	48	1.6	<b>039805</b> ●
30	140	145	229	63	48	1.9	<b>663071</b> ●
35	192	197	281	63	52	2.6	<b>039806</b> ●

Sales unit consisting of arbor, clamping screw and conical spring washer (flat design) with safety device against twisting, without spacers.

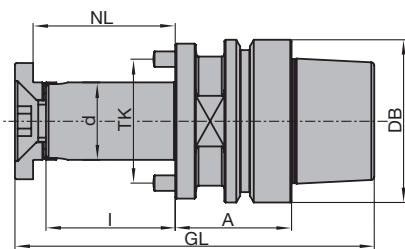

Arbor HSK-E 63

**Spare parts:**

BEZ	ABM	for d	ID
	mm	mm	
Washer with safety device against twisting, M10	20/35x13x10.5	20	<b>006768</b> ●
Washer with safety device against twisting, M16	30/45x15x16.5	30	<b>006769</b> ●
Washer with safety device against twisting, M16	35/50x15x16.5	35	<b>006770</b> ●
Chip-Balluff	511 Bytes		<b>081309</b> ●
Chip-Balluff	2047 Bytes		<b>081330</b> □

Suitable spacers, see section Knives and Spare Parts.

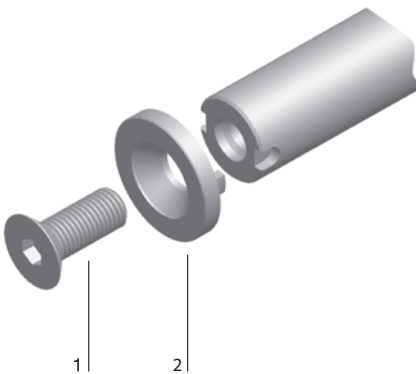

- 1 Clamping screw
- 2 Conical spring washer for safety against twisting



### Cutting arbor with hollow taper shank HSK-F 63

#### Application:

Arbor for single tools with bore or tool sets with bore.

#### Technical information:

Hollow taper shank design as per DIN 69893. Safety device against tool twisting by screw or pin. Arbors are fine balanced. Spring washers with safety against twisting. For suitable mounting device VN 799 0, see section Knives and Spare Parts.

**Note:** Preferably use the short model for low vibration cutting. Please comply with the specifications regarding the maximum admissible weight and diameters detailed by the machine manufacturer.

#### HSK-F 63, DIN 69893, A = 45 mm

TI 501 0 07

d	l	NL	GL	DB	TK	Weight	ID
mm	mm	mm	mm	mm	mm	kg	
20	70	75	152	63	32	1.2	<b>042987 ●</b>
30	80	85	162	63	48	1.6	<b>042988 ●</b>
30	140	145	222	63	48	1.9	<b>041426 ●</b>
35	192	197	274	63	52	2.6	<b>041425 ●</b>

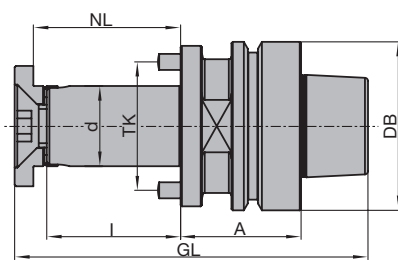

Arbor HSK-F 63

#### HSK-F 63, DIN 69893, A = 80 mm

TI 501 0 07

d	l	NL	GL	DB	TK	Weight	ID
mm	mm	mm	mm	mm	mm	kg	
20	70	75	187	63	32	1.7	<b>042847 ●</b>
30	80	85	197	63	48	2.1	<b>042951 ●</b>
30	120	125	237	63	48	2.4	<b>041427 ●</b>

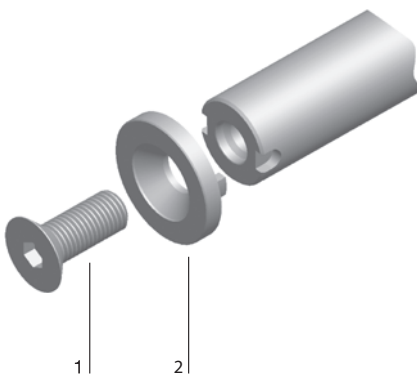

- 1 Clamping screw  
2 Conical spring washer for safety against twisting

#### HSK-F 63, DIN 69893, A = 90 mm

TI 501 0 07

d	l	NL	GL	DB	TK	Weight	ID
mm	mm	mm	mm	mm	mm	kg	
35	170	175	297	63	52	3.2	<b>041428 ●</b>

Sales unit consisting of arbor, clamping screw and conical spring washer (flat design) with safety device against twisting, without spacers.

#### Spare parts:

BEZ	ABM	for d	ID
	mm	mm	
Washer with safety device against twisting, M10	20/35x13x10.5	20	<b>006768 ●</b>
Washer with safety device against twisting, M16	30/45x15x16.5	30	<b>006769 ●</b>
Washer with safety device against twisting, M16	35/50x15x16.5	35	<b>006770 ●</b>
Chip-Balluff	511 Bytes		<b>081309 ●</b>
Chip-Balluff	2047 Bytes		<b>081330 □</b>

Suitable spacers, see section Knives and Spare Parts.

### Cutting arbor with hollow taper shank HSK-F 63 mod.



#### Application:

Arbors for single tools with bore or tool sets with bore. For precise clamping in the machine spindle and quick tool change, mainly on Homag through feed machines with HSK-F 63 mod. motor spindle.

#### Machine:

Double-end tenoner, flooring machines, edgebanding machines etc.

#### Technical information:

Fine balanced arbors with hollow shank taper modified design as per DIN 69893 HSK-F 63. Precise tool clamping for high concentricity. Clamping screws and end ring are part of the arbor.

#### HSK-F 63 mod., A = 12.5 mm and 52 mm

TB 300 0

Machine	d	l	NL	A	GL	DB	TK	Weight	ID
	mm	mm	mm	mm	mm	mm	mm	kg	
Homag	60	28	28	52	105	63	75	2.1	<b>663052</b> ●
Homag	60	59.5	54.5	12.5	99	63	75	2.2	<b>663053</b> ●

#### Spare parts:

BEZ	ABM	ID
	mm	
Cylindrical screw with ISK	M6x30	<b>005928</b> ●
Cylindrical screw with ISK	M6x65	<b>005935</b> ●
Allen key	SW 5	<b>005452</b> ●

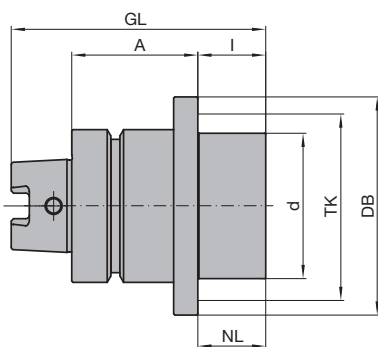

Arbors HSK-F 63 mod. (ID **663052**) with flange

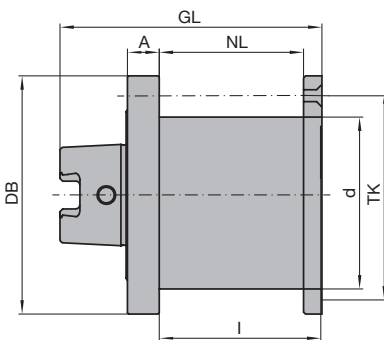

Arbor HSK-F 63 mod. (ID **663053**) with end ring and clamping screws



### Cutting arbor with hollow shank taper HSK 85 WS

**Application:**

For mounting saws, cutting tools, sets of cutting tools and cutterheads.

**Machine:**

Machines with HSK 85 WS adaptor e.g. moulders (Weinig Powermat), window production machines etc.

**Technical information:**

Easy and safe handling with optional lifting rings.

**HSK 85 WS, A = 26 mm, for Weinig Powermat without safety device against twisting**

TI 501 0 14

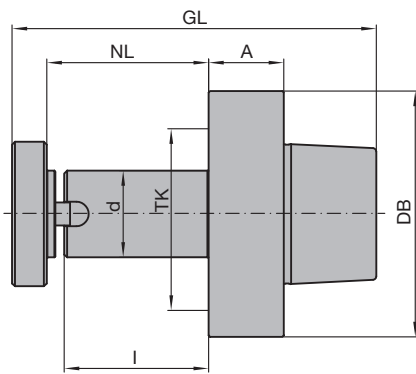

Cutting arbor HSK 85 WS with clamping spacer and safety device against twisting

Machine	d mm	l mm	NL mm	GL mm	DB mm	TK mm	Weight kg	ID
Weinig	30	50	55	125	85	48	1.7	663101 ●
Weinig	30	80	85	155	85	48	1.9	663102 ●
Weinig	30	105	110	180	85	48	2.0	663103 ●
Weinig	40	80	85	155	85		2.3	663075 ●
Weinig	40	100	105	175	85		2.5	663083 □
Weinig	40	130	135	205	85		2.8	663077 ●
Weinig	40	145	150	220	85		3.0	663084 □
Weinig	40	165	170	240	85		3.3	663078 ●
Weinig	40	205	210	280	85		3.6	663085 □
Weinig	40	235	240	310	85		4.2	663079 ●
Weinig	50	80	85	155	85		2.9	663076 ●
Weinig	50	100	105	175	85		3.2	663086 □
Weinig	50	130	135	205	85		3.7	663080 ●
Weinig	50	145	150	220	85		3.9	663087 □
Weinig	50	165	170	240	85		4.7	663081 ●
Weinig	50	205	210	280	85		4.8	663088 □
Weinig	50	235	240	310	85		5.3	663082 ●

**Spare parts:**

BEZ	ABM mm	for d mm	ID
Washer with safety device against twisting	50/20	30	008376 ●
Washer with safety device against twisting	60/20	40	008368 ●
Washer with safety device against twisting	70/20	50	008369 ●
Cylindrical screw with ISK	M8x20	40/50	114048 ●



#### Cutting arbor with hollow shank taper HSK 85 WS

**Application:**

For mounting saws, cutting tools, sets of cutting tools and cutterheads.

**Machine:**

Machines with HSK 85 WS adaptor e.g. moulders (Weinig Powermat), window production machines etc.

**Technical information:**

Easy and safe handling with optional lifting rings.

**HSK 85 WS, A = 26 mm, for Weinig Powermat with two safety device grooves against twisting in the HSK**

TI 501 0 16

Machine	d mm	l mm	NL mm	GL mm	DB mm	Weight kg	ID
Weinig	40	165	170	240	85	3.2	663104 □
Weinig	40	235	240	310	85	3.9	663105 □
Weinig	60	105.5	100	176	85	4.2	663106 ●

**Spare parts:**

BEZ	ABM mm	for d mm	ID
Washer with safety device against twisting	60/20	40	008370 ●
Washer with safety device against twisting	90/18	60	008379 ●
Cylindrical screw with ISK	M8x20	40/60	114048 ●

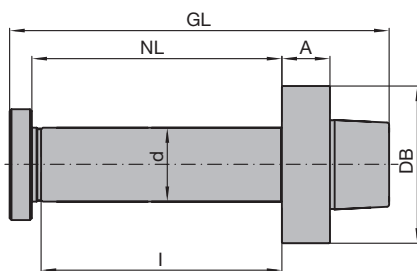

Cutting arbor HSK 85 WS with clamping spacer and safety device against twisting in HSK.



#### Cutting arbor with hollow shank taper HSK 85

**Application:**

For mounting saws, cutting tools, sets of cutting tools and cutterheads.

**Machine:**

Machines with HSK 85 WS adaptor e.g. moulders, window production machines etc.

**Technical information:**

Easy and safe handling with optional lifting rings.

**HSK 85, A = 33 mm and A = 26 mm, for SCM**

TI 501 0 14

Machine	d mm	l mm	NL mm	GL mm	DB mm	Weight kg	ID
SCM	40	125	130	207	85	2.6	663061 ●
SCM	50	325	320	413	85	7.3	663055 ●

**Spare parts:**

BEZ	ABM mm	for d mm	ID
Washer with safety device against twisting	60/20		008368 ●
Washer with safety device against twisting	70/20	50	008375 ●
Cylindrical screw with ISK	M8x20	40	114048 ●
Cylindrical screw with ISK	M8x35	50	006524 ●

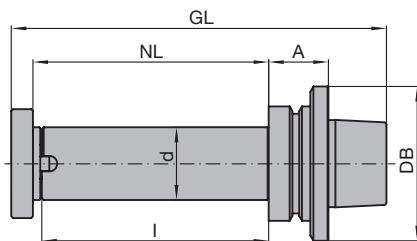

Cutting arbor HSK 85 - TI 501 0 14



**Blanking arbor HSK 85 WS**

**Application:**

Dust cover for spindles when not in use.

**Machine:**

Machines with HSK 85 WS adaptor e.g. moulders (Weinig Powermat), window production machines etc.

**Blanking arbor for Weinig Powermat**

TI 501 0 14

Machine	ID
Weinig	663044 ●



**Lifting ring, HSK 85 WS**

**Application:**

Lifting rings can be mounted on arbors for easy and safe tool handling.

**Lifting ring for HSK 85 WS arbors**

TK 540 0

Machine	BEZ	ABM mm	TK mm	ID
Weinig	Spindle lifting rings	for d=30 with safety device against twisting	18	008378 ●
Weinig	Spindle lifting rings	for d=40 with safety device against twisting	25	008365 ●
Weinig	Spindle lifting rings	for d=50 with safety device against twisting	32	008366 ●

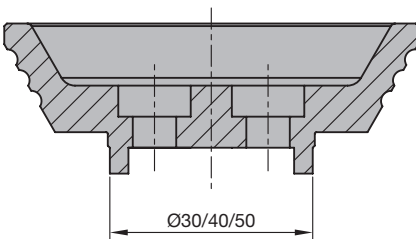

ID 008378/ 008365 / 008366

## 7. Clamping systems

### 7.4 Clamping arbors

#### 7.4.3 Adaptors for circular sawblades

<b>Application</b>	Clamping and mounting of circular sawblades.
<b>Machines</b>	Stationary routers with CNC control and spindles for automatic tool change. Milling machines with cutting spindles for automatic tool change.
<b>Technical features</b>	<p>Circular sawblade adaptors are used to mount sawblades on CNC machining centres or through feed machines with automatic tool change tool spindles.</p> <ul style="list-style-type: none"> <li>- Design without flange suitable for deep mitre cuts on 5-axis CNC machining centres.</li> <li>- Design with clamping flange for precise cuts and multi purpose applications.</li> <li>- Multi-purpose design for variable applications on all arbors with diameter <math>d = 30</math> mm.</li> </ul>



Sawblade mounting flange with HSK-F 63 adaptor.

<b>Allowed bore tolerances</b>	Circular sawblades mounted on sawblade flanges have to have the following bore tolerances:	
		<b>Bore tolerance</b>
	Circular sawblade for sawblade flange	ISO H7





#### Tool adaptor for circular sawblades for CNC aggregates

##### Application:

Tool adaptor with flange for the adaption of circular sawblades.

##### Technical information:

Steep taper design for Flex 5+ aggregate (Homag Group) and 5-motion-Plus aggregate (Felder Format-4). The circular sawblade is fixed through 8 countersink screws M5 on the flange. Maximum sawblade diameter 220 mm (limitation through the aggregate). The maximum cutting width of sawblade is limited to 6 mm. Tool adaptor is fine balanced.

##### Sawblade adaptor

TI 501 0

Machine	d	l	NL	A	GL	DB	TK	Weight	ID
	mm	mm	mm	mm	mm	mm	mm	kg	
Felder Format-4,	40	2.5	2,5	23.5	62.5	40	52	0.4	<b>663074 ●</b>
Homag Group			- 4						

##### Spare parts:

BEZ	ABM	ID
	mm	
Countersink screw, Torx® 20	M5x12	<b>006247 ●</b>
Torx® key	Torx® 20	<b>117511 ●</b>

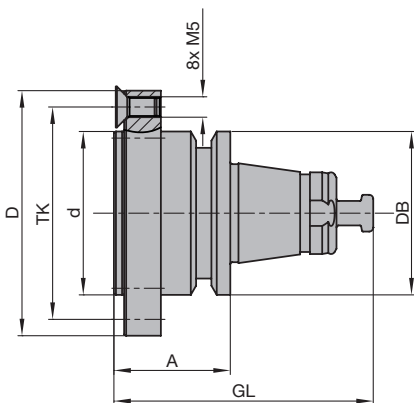

Saw blade adaptor



### Tool adaptor for circular sawblades

#### Application:

Tool adaptor with flange for the adaption of circular sawblades.

#### Technical information:

Optionally mounting the sawblade by means of counterscrews or with the enclosed counterflange. Mounting with counterflange is preferred for increased stability and concentricity in case of precision cuts. Application without counterflange is preferred for producing mitre and rafter cuts. Maximum diameter of sawblade 350 mm (450 mm with counter flange).

#### HSK-F 63, DIN 69893

TI 501 0 07

Machine	d	l	NL	A	GL	DB	TK	Weight	ID
	mm	mm	mm	mm	mm	mm	mm	kg	
Homag	30	2.5	2.5 - 3.5	40	75.5	63	90	2.0	<b>663094 ●</b>
	30	2.5	2.5 - 3.5	50	85.5	63	90	2.2	<b>663093 ●</b>
SCM	30	2.5	2.5 - 3.5	60	95.5	63	90	2.5	<b>663109 ●</b>

Sales unit consisting of HSK-flange with counterscrews as well as counterflange with cylindrical screws.

#### Spare parts:

BEZ	ABM	ID
	mm	
Cylindrical screw with ISK	M5x12	<b>006414 ●</b>
Countersink screw, Torx® 20	M5x8.5	<b>007808 ●</b>
Allen key	SW 4, L 71	<b>005468 ●</b>
Torx® key	Torx® 20	<b>117511 ●</b>

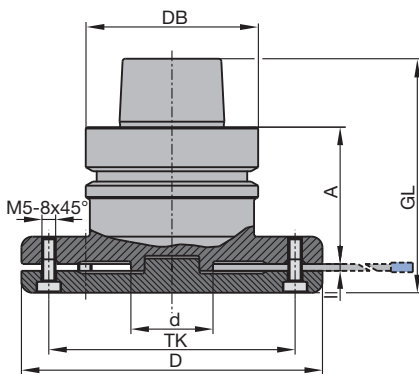

Clamping variant with counter flange

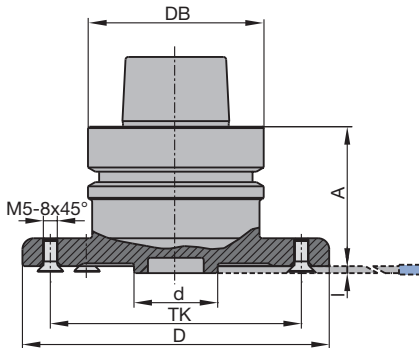

Clamping variant with concentrically mounted sawblade

## 7. Clamping systems

### 7.4 Clamping arbors

#### 7.4.3 Adaptors for circular sawblades



#### Flange for circular sawblades

##### Application:

To mount circular sawblades on arbors.

##### Technical information:

Sawblade flange is mounted on arbor with diameter  $d = 30$  mm by clamping screws and pins. The length and the dimension A are flexible and defined by spacers. Maximum sawblade diameter 350 mm.

##### Flange adaptor

TR 810 0

Machine	D	H	BO	NL	TK	Weight	ID
	mm	mm	mm	mm	mm	kg	
Universal	110	22	30	2 - 3.5	90	0.9	<b>066752 ●</b>

##### Spare parts:

BEZ	ABM	ID
	mm	
Countersink screw, Torx® 20	M5x12	<b>006247 ●</b>
Torx® key	Torx® 20	<b>117511 ●</b>
Spacer with cylindrical pins	60x20x30	<b>028674 ●</b>

Suitable spacers, see section Knives and Spare Parts.

Clamping length L depending on spacer thickness X and the dimension A of the arbor used:

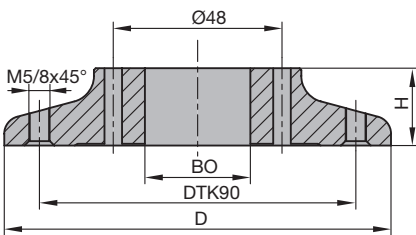

Flange TR 810 0

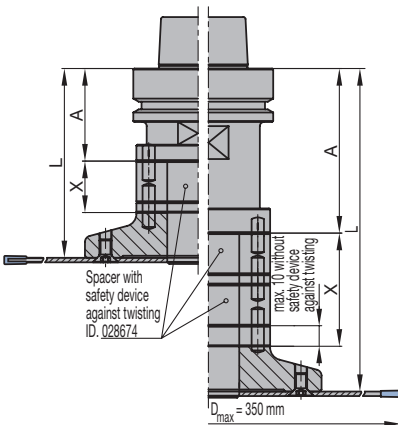

##### Note:

Variable clamping length through the combination of spacers without pins and spacers with pins for the safety device against twisting ID **028674**. Maximum thickness of the spacers without safety device against twisting = 10 mm.

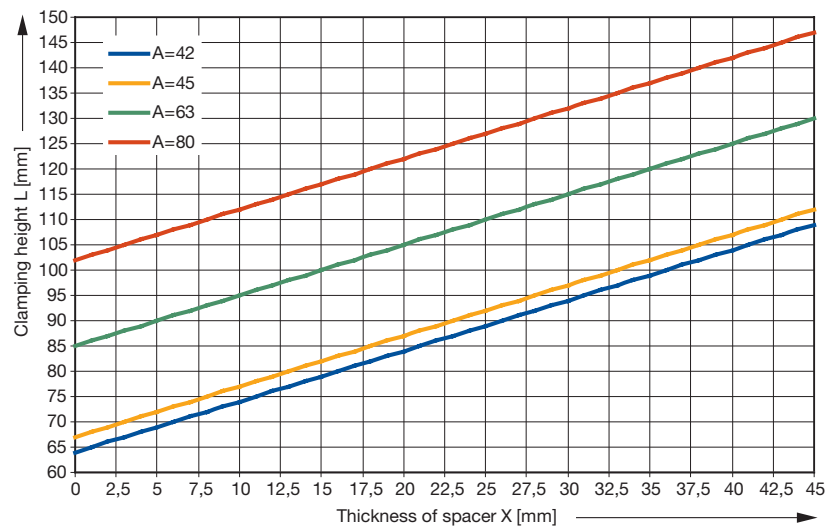

# Key to pictograms

---



Spindle without twist protection



Spindle with anti-twist keyway



Spindle with anti-twist hexagon



Hydro clamping system - open



Hydro clamping system - closed



Hydro-Duo (bi-directional) clamping



Hydro clamping arbors



Hydro clamping

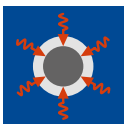

Shrink-fit clamping



Quick clamping system

---

